



# Twin Spark Super head+R Kit Instruction Manual

Item No. : 0 1 - 0 3 - 0 7 5 6

Compatible models and the frame No.:

Ape100 : HC07-1600001 ~

Ape100 Type D : HC13-1000001 ~

(All models need to be equipped with a secondary air supply system.)

- Thank you for purchasing one of our products. Please strictly follow the following instructions in installing and using the kit.
- Before installing the kit, please be sure to check the kit contents. Should you have any questions about the kit, please contact your local motorcycle dealer.

**Please note that, in some cases, the illustrations and photos may vary from the actual hardware.**

## ~ Features ~

This is TAKEGAWA originally designed Cylinder Head. Both of intake and exhaust valves are enlarged while diameters of valve stem shafts are thinned down. Furthermore, valve angles, port designs and combustion chamber designs are all originally designed by TAKEGAWA. Even more combustion efficiency with twin spark system. Also, the camshaft has a specialized cam holder and is now supported by ball bearings at the journals. Oil passages is redesigned and the camshaft has a hollow construction. By injecting the oil from the camshaft, the lubricity and the cool capability are increased. Roller bearings are incorporated in valve rocker arms. The increased weight because of the built-in bearings are offset with the decreased weight by using the forged aluminum. We guarantee your satisfaction.

## Read all instructions first before starting the installation

We do not take any responsibility for any accident or damage whatsoever arising from the use of the kit not in conformity with the instructions in the manual. Please note that this kit is designed for exclusive use in the above-mentioned applicable models and frame numbers only and that it cannot be mounted on other models.

Installation of this kit requires engine removal and crankcase disassembly. Please do the installation work with utmost care, referring to the Honda's genuine service manual for the above-mentioned compatible models. Besides, this instruction manual, as well as the HONDA's genuine service manual, is prepared with those persons in mind who have basic skills and knowledge. Therefore, we recommend those who are technically inexperienced or do not have enough tools to ask a technically-reliable specialist shop for the work.

We shall be held free from any kind of warranty whatsoever of products other than this product if the glitch takes place on the other products than this one after the installation and use of this product.

You are kindly requested not to contact us about the combination of our products with other manufacturers'.

A serial number is stamped on the cylinder head. You may be requested to inform us of the number when ordering small parts.

Some of bolts, nuts, dowel pins and packings will be reused. However, be sure to replace worn-down or severely-damaged ones with new ones.

Do not use liquid packings, which may opilate oil passage; it may break the engine in the worst case.

Be sure to always use premium unleaded petrol. And make sure to check what kind of gasoline is remaining in the fuel tank. Whenever regular gasoline remains in the fuel tank, always replace it with high-octane gasoline.

Determine the heat value of a spark plug depending on how much it is burnt. In vehicles originally with a resistor plug, always use a resistor plug.

Never use this kit on the point-ignition system motorcycle.

Please be informed that what we can safely say is that the ignition system is compatible only with ours and stock ignition systems, because no data is available with us on the compatibility with other ignition systems. Therefore, please never use other ignition systems, which may cause technical troubles.

Install an oil cooler when necessary.

Engine oil must be API SF or higher class, such as SAE 10W-40 / 15W-50, which are our recommendations.

Change a sprocket with the one which corresponds to the engine output power and specifications.

This kit cannot perform on its own. Please see "Engine Parts Recommended by TAKEGAWA" on page 2.

This kit is only compatible with those engine parts recommended by us. So, please replace the engine parts not recommended by us with those of our recommendations.

This kit is intended for closed course competition purposes only. So, take note that it is prohibited to drive your motorcycle on a public road after the installation of this kit. Drive your motorcycle at a legal speed, abiding by the laws.

If you have purchased a cylinder head kit only, the camshaft is an optional part. Please separately purchase the special camshaft for exclusive use with this kit.

The sub-plug is not waterproof around the plug cap. So, regular checking is needed, and you have to be careful in riding in the rain for not exposing the plug to the rain.

## Quick Starting and Sudden Acceleration

Please note that idling, sudden acceleration, and sudden engine braking will put a heavy load on the engine. It may result in crankshaft damage and engine breakage in the worst case.

Please be informed that, mainly because of improvement in performance, design changes, and cost increase, the product specifications and prices are subject to change without prior notice.

This manual should be retained for future reference.



### CAUTION

The following show the envisioned possibility of human death or serious injuries to human bodies as a result of disregarding the following cautions.

- This kit is intended for closed course competition purposes only. So, take note that it is prohibited to drive your motorcycle on a public road after the installation of this kit. Drive your motorcycle at a legal speed, abiding by the laws.
- Make sure the engine and muffler are completely cool at below 35 degrees C before starting the installation. (Otherwise, you will burn yourself.)
- Do the installation with right tools. (Otherwise, breakage of parts or injuries to yourself may take place.)
- As some products and frames have sharp edges or protruding portions, please work with your hands protected. (Otherwise, you will suffer injuries.)
- Always use new gaskets, and seals. And check those parts to be reused for wear and damage. If you find worn or damaged parts, replace them with new ones.

**WARNING** The following show the envisioned possibility of human death or serious injuries to human bodies as a result of disregarding the following cautions.

- Those who are technically unskilled or inexperienced are required not to do the work. (Improper installation because of insufficient skill and knowledge could lead to parts breakage and subsequently to accidents.)
- Before doing work, make sure your motorcycle is secure on level ground for safety's sake. (Otherwise, your motorcycle could overturn and injure you while you are working.)
- Always start the engine in a well-ventilated place, and do not turn on the engine in an airtight place. (Otherwise, you will suffer from carbon monoxide poisoning.)
- As gasoline is highly flammable, never place it close to fire. Make sure that nothing flammable is near the gasoline. Since vaporized accumulation of gasoline is at high risk of explosion, work in a well-ventilated place. (Otherwise, it may cause a fire.)
- Always use a torque wrench to screw bolts and nuts tight and securely to the specified torque. (Otherwise, these parts may get damaged or fall off, resulting in accidents.)
- If you find damaged parts when checking and performing maintenance of your motorcycle, do not use these parts any longer, and replace them with new ones. (The continued use of these damaged parts could lead to an accident.)
- When you notice something abnormal with your motorcycle while riding, immediately stop riding and park your motorcycle in a safe place to check what has gone wrong. (Otherwise, the abnormality could lead to accidents.)
- Before riding, be sure to check every section for slack in parts like screws, and oil leak. When you notice something abnormal with your motorcycle while riding, immediately stop riding and park your motorcycle in a safe place to check what has gone wrong. (Otherwise, the abnormality could lead to accidents.)
- Check or carry out maintenance of your motorcycle correctly according to the procedures in the instruction manual or service manual. (Improper checking or maintenance could lead to accidents.)
- Be sure to always use premium unleaded petrol. (Otherwise, troubles such as knocking of an engine may cause accidents.)

### Safety precautions to take before riding

About fuel:

Always replace the regular gasoline with high-octane gasoline when it is remaining in the fuel tank.

With this kit installation, a centrifugal filter will be lost. So, please install a dry-type clutch with an external oil filter or a special clutch.

About change of sprocket:

The installation of this kit will increase the power. So the continued use of a stock sprocket will result in severe wears of parts because of too low gear, not only adversely affecting the engine life, but also breaking the engine in the worst case. Therefore, please change the sprocket with the high-geared one.

### Engine Parts Recommended by TAKEGAWA

This kit is only compatible with those engine parts recommended by us. So, please replace the engine parts not recommended by us with those of our recommendations.

Recommended Parts	
Clutch	Dry-Type Clutch Special 5-Disk Clutch Kit
Ignition System	Hyper C.D.I. C.D.I. Magnet Kit
Carburetor	KEIHIN PE28 Carburetor Kit
Oil Pump	Super Oil Pump
Muffler	Racing Muffler
Cam Chain	DAI-HARD

**If you have bought a head kit only, this head kit alone does not work. Please purchase a special bore-up kit with reference to the attached sheets.**

Others:

About oil cooler:

The installation of this kit increases the heat release value of the engine, set off by the increase in power. For a long-time, high-load running, we recommend you to install an oil cooler kit which keeps the oil at appropriate temperatures and prevents such troubles as lack of oil film at high temperatures.

About camshaft and rocker arm:

If you have purchased a cylinder head kit alone, a special camshaft is needed separately. Camshafts with a few kinds of profiles are available from us to meet different uses and engine displacement. Even if you have purchased a full kit, you can study to use them as an optional extra in addition to the supplied camshafts. For more information, please refer to the attached sheet.

This cylinder head has TAKEGAWA originally designed camshaft and rocker arms. Be sure to use the rocker arms and the camshaft included in the kit. Stock rocker arms cannot be used.

### Upper limit of revolution

Upper limit of revolutions varies depending on the installed cam shaft, etc. Referring to the camshaft comparison graph on page A3, install a revolution counter to make sure that you drive the engine at revolutions below maximum output speed r.p.m.

Take note that idling and sudden acceleration, particularly in the 1st or 2nd gear, tend to exceed the upper limit of revolutions. Over revolutions will result in nonsmooth revolutions of the engine, not only adversely affecting the engine life, but also possibly breaking the engine in the worst case.

### Titanium valve spring retainer (optional)

This Super Head has optional titanium valve spring retainers. Titanium retainers are about 30% lighter than steel retainers. The surface is treated with a special coating of which hardness is HV1000 above for added shock-resistance and wear-resistance. Item No.01-12-084(2 pcs)



A serial number is stamped on the cylinder head for administration purpose. You may be requested to inform us of the number when ordering repair parts. In case you cannot place an order with us because you do not have the repair part Item No., please place an order with us referring to the example below.

Take a note of the number stamped on the side of the cylinder head.  
Head No.- SPH-30001  
example of ordering : Super Head Kit, Repair Head No.- SPH-30001 one pc of intake valve

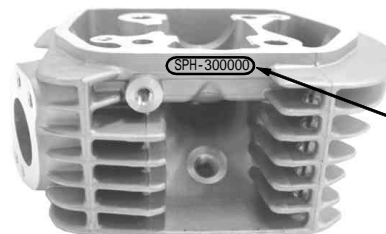

A serial No. is stamped here:  
SPH-300\*\*\*

For those who have purchased a cylinder head kit alone, selection kits are available to meet your combination demand depending on the specifications, etc. Please study the required contents of the kit, referring to the attached sheets. For more details and enquiries, please contact your local motorcycle dealer.

### About optional camshaft:

The following camshafts, compatible with this kit, are available from us.

Referring to the list below, please select a camshaft to match your usage and engine displacement, for your great riding pleasure.

SR-25 camshaft	Included in bore-up, and bore- and stroke-up kits	01-08-0445
SR-30 camshaft	Optional	01-08-0446
SR-35 camshaft	Optional	01-08-0447

#### About Camshafts Number

The bigger the numbers of XX/YY are, the wider the durations are. With these camshafts, the output power will produce more to high rpm range. While, the smaller the numbers are, the narrower the durations are. With these camshafts, the output power will produce more to low-to-mid rpm range. We supply the suitable camshaft depending on the displacements.

When choosing the optional camshafts, please choose the camshaft referring to the camshaft data chart to suit your riding purpose.

Also, the engine output will vary significantly depending on the using exhaust system, length of inlet pipe, carburetor diameter, compression ratio, ignition system, ignition timing, fuel or natural phenomenons such as ambient temperature or atmospheric pressure.

### Comparison data of camshaft

NB: As these are the data measured on a Dyno Jet, the data differ from the actual driving. So, please refer to them just as a reference. The engine power varies significantly depending on the temperatures.

136 cc

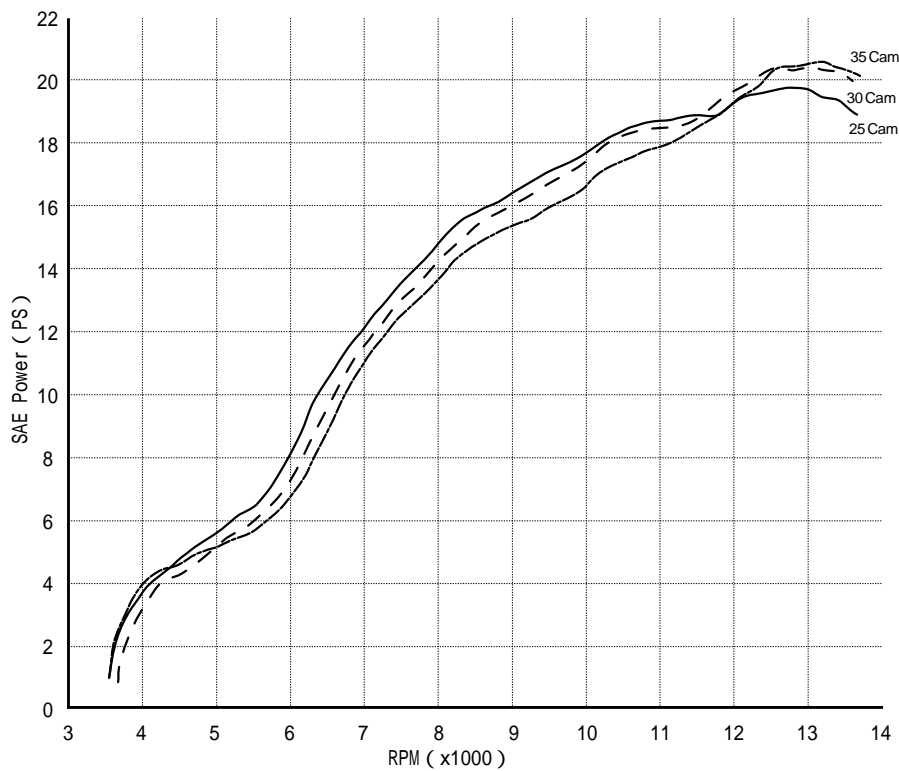

Cam comparison when this kit is used in 136cc Ape models.

- SR25 camshaft (The supplied camshaft)
- - - SR30 Racing camshaft
- · - · SR35 Racing camshaft

~ Kit Contents ~

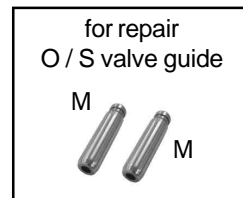
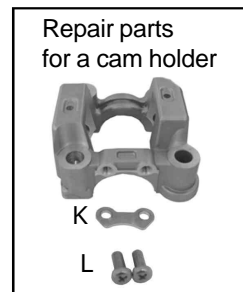
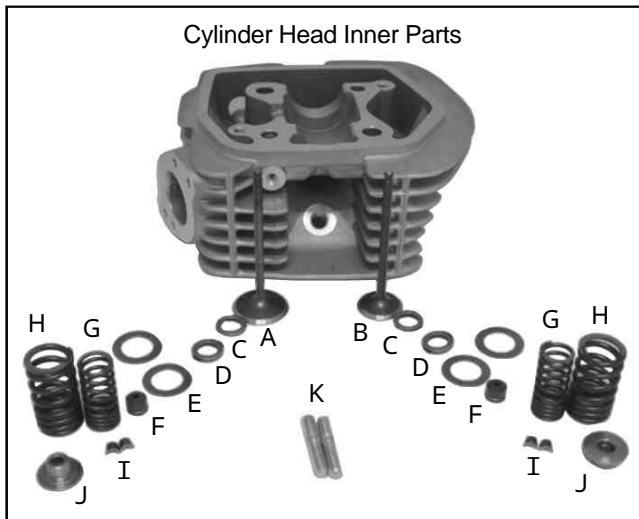
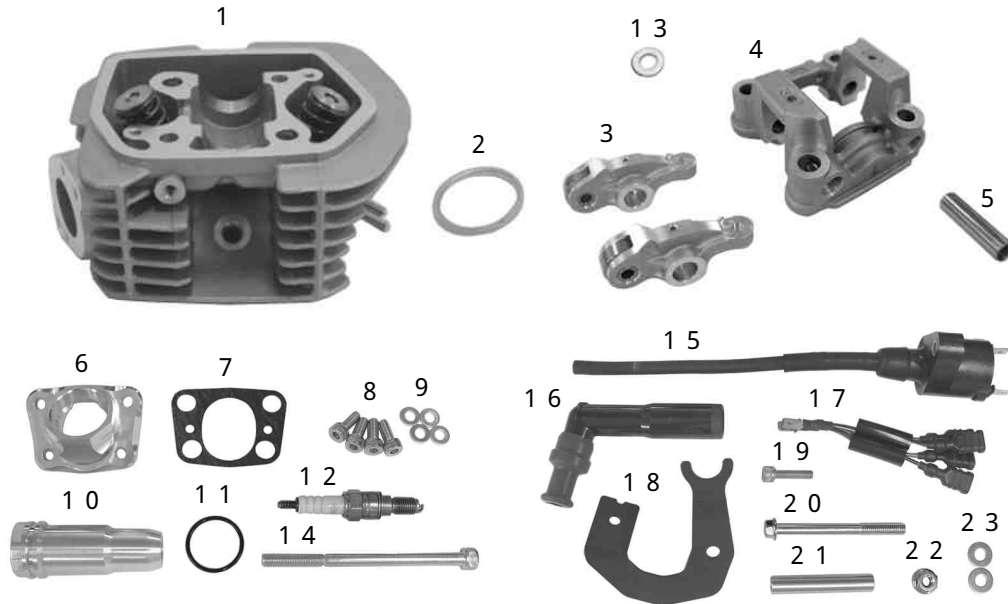

No.	Part Name	Qty	Repair Part Item No.	In packs of	No.	Part Name	Qty	Repair Part Item No.	In packs of
1	Cylinder Head Assembly	1	06120-149-T90	1	13	Sealing washer, 6.5x12	1	00-00-2780	1
2	Exhaust Pipe Gasket	1	00-01-0027	2	14	Bolt, 6 x 90	1	00-00-0263	2
3	Rocker Arm	2	14431-SP4-T00	1	15	Ignition coil	1	00-05-0011	1
4	Cam Holder COMP.	1	00-01-1035	1	16	Spark plug cap	1	30700-TSP-T00	1
5	Rocker Arm shaft	1	14451-SP4-T00	1	17	Ignition coil sub cord	1	30530-GEF-T00	1
6	Spark plug sleeve adapter	1	12341-TSP-T00	1	18	Ignition coil stay COMP.	1	30520-TSP-T00	1
7	Spark plug sleeve adapter gasket	1	12395-TSP-T00	1	19	Bolt, 5 x 20	1	00-00-0264	6
8	Bolt, 5 x 12	4	00-00-0260	6	20	Bolt, 6 x 65	1	00-00-0034	4
9	Sealing washer	4	00-00-0261	4	21	Distance collar	1	15664-GCR-T00	1
10	Spark plug sleeve	1	12351-TSP-T00	1	22	Flange nut, 6 mm	1	00-00-0173	6
11	O ring, 22.1 mm	1	00-00-0262	3	23	Plain washer, 6 mm	2	00-00-0086	10
12	Spark plug	1	NGK-ER8EH	1		Alumi Special ( 5 g )	1	00-01-0001	1
No.	Part Name	Qty	Repair Part Item No.	In packs of	No.	Part Name	Qty	Repair Part Item No.	In packs of
A	Intake Valve	1	14711-149-T42	1	I	Valve Cotter	4	00-01-0018	4
B	Exhaust Valve	1	14721-149-T42	1	J	Valve Spring Retainer	2	00-01-0078	2
C	Valve Spring shim, Inner	1	00-01-0257	2	K	Stud Bolt	2	00-01-0073	2
D	Valve Spring Seat, Inner	2	00-01-0072(SET)	2	L	Cam Stopper	1	12211-SPH-T00	1
E	Valve Spring Seat, Outer	4		2	M	Pan Screw, 5x12	2	00-00-0600	5
F	Valve Stem Seal	2	00-01-0015(SET)	2	N	Valve guide O/S	2	00-01-0074	1
G	Inner Valve Spring	2	00-01-1036(SET)	2					
H	Outer Valve Spring	2		2					

Please note that in ordering repair parts, be sure to quote the Repair Part Item No. Otherwise, we may not be able to accept your orders. There are some parts, however, for which we are not in a position to accept your order in just the quantity to be used. In this case, please take them in the quantity packed.

**SPECIAL PARTS TAKEGAWA Co.,Ltd.**  
3-5-16 Nishikiorihigashi Tondabayashi Osaka Japan TEL:81-721-25-1357 FAX:81-721-24-5059 URL: http://www.takegawa.co.jp

## ~ Installation Procedures of Cylinder Head ~

Degrease the mating surfaces of the cylinder and the cylinder head with thinner.



Fix two dowel pins and a cylinder head gasket to the cylinder.

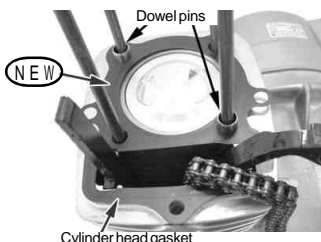

Pass the cam chain through the cylinder head, and install the cylinder head.



Pass the adjuster through the cam chain tensioner and cylinder head to attach it.



Temporarily tighten a set plate with a locking bolt.



Temporarily tighten a cylinder head mounting bolt.

When installing a camshaft:

Loosen an adjusting nut on the standard rocker arm attached to the camshaft holder.



Remove a rocker arm from the camshaft holder.

- Lightly screw 8mm bolt(s) to the rocker arm shaft on the exhaust side, and pull out the rocker arm shaft.
- Push the inlet-side rocker arm shaft with a screwdriver or the like, and then remove the rocker arm shaft.

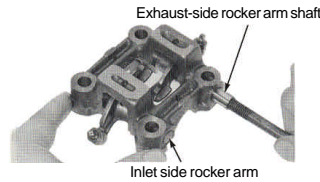

Inspect your inlet side's rocker arm shaft.  
Service limit: 9.91 mm. Change the rocker arm shaft of below this 9.91 mm.



Install the included rocker arms on the kit's camshaft holder.

- Apply the molybdenum oil to the cutout of the inlet rocker arm shaft and install it.

When installing it, align the cutout of the inlet rocker arm shaft and bolt hole of camshaft holder. On the EX side, install the supplied rocker arm shaft with the thread side facing out. The EX side (the supplied shaft) does not have the cutout.



Apply engine oil to the adjusting bolt and adjusting nut of the removed stock rocker arm, which please install to the supplied rocker arm.

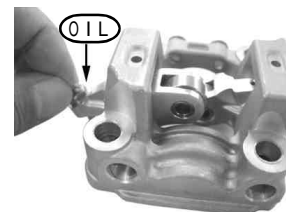

Remove an oil check bolt on the standard cylinder head.



Apply the engine oil to the supplied camshaft bearings and install the camshaft with the cam lobes facing down on the cylinder head.

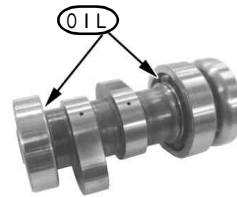

Attach two dowel pins and install a camshaft holder.

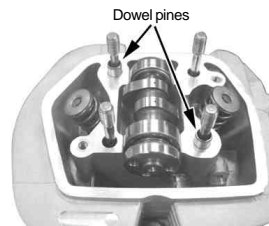

Attach 4 washers and slightly apply "Aluminum Special", the heat-resistant lubricating agent, to the seating faces of 4 nuts, and equally tighten them up in a few steps diagonally.

⚠ Caution: Apply the specified torque.

**Torque: 20 N · m (2.0 kgf · m)**

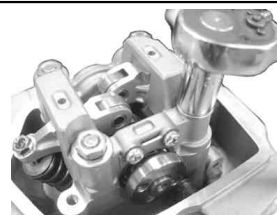

Securely tighten the temporarily-tightened cylinder head mounting bolt.

⚠ Caution: Apply the specified torque.

**Torque: 12 N · m (1.2 kgf · m)**

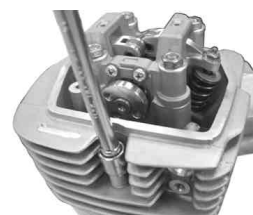

Check that "T" mark on the fly wheel is aligned with the " " mark on the crankcase.

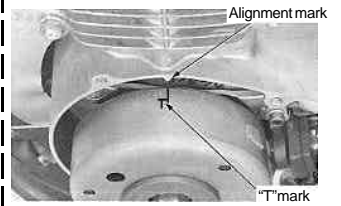

Install the cam chain with the "O" mark on the cam sprocket facing upwards, and fit the cam sprocket into the camshaft.

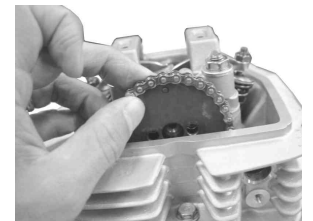

Aligning the bolt hole on the camshaft with the cam sprocket, tighten two hex bolts loosely. At this point, fix a knock bolt (black bolt) on the intake side.

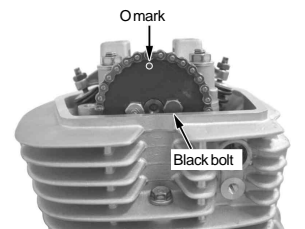

Holding a flywheel, tighten up two hex bolts on the cam sprocket.

⚠ Caution: Apply the specified torque.

**Torque: 12 N · m (1.2 kgf · m)**

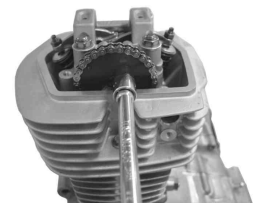

Adjust the cam chain. By turning flywheel counterclockwise 180 degrees, set up two cam lobes of the camshaft facing upward.



Turning the flywheel by hand, feel the level of tension with the cam sprocket. And turn the flywheel up to the point where you get the proper tension and you can turn the flywheel freely without sticking. At this point, tighten the locking bolt and fix the adjuster.

⚠ Caution: Apply the specified torque.

**Torque: 10 N · m (1.0 kgf · m)**

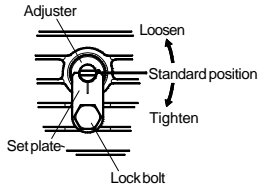

In case you can not get the proper tension of the cam chain only by adjustment of the adjuster, then adjust the tension with the adjusting bolt on the cylinder.



⚠ Caution: Apply the specified torque.

**Torque: 12 N · m (1.2 kgf · m)**

By turning flywheel counterclockwise 180 degrees, set up the "O" mark of cam sprocket straight up, and align the "T" mark of flywheel with the " " mark of crankcase.

Adjust the valve clearance with an adjusting screw.  
IN :0.08 (when cold) ± 0.03  
EX:0.08 (when cold) ± 0.03



Holding the adjusting screw, tighten the adjusting nut.

⚠ Caution: Apply the specified torque.

**Torque: 10 N · m (1.0 kgf · m)**



After tightening the nut, insert the thickness gauge again to check the valve clearance.

Fill the oil reservoir on the cylinder head with clean engine oil.

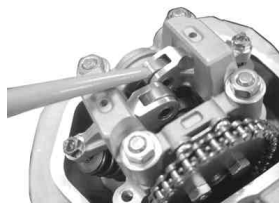

Install the supplied sealing washer and the STD oil check bolt. Then tighten them to the specified torque.

⚠ Caution: Apply the specified torque.

**Torque: 8 N · m (0.8 kgf · m)**

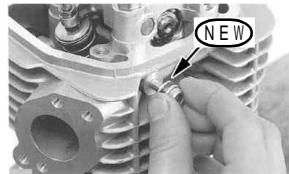

Install the cylinder head cover and its gasket onto the cylinder head with two cylinder head cover bolts.

⚠ Caution: Apply the specified torque.

**Torque: 12 N · m (1.2 kgf · m)**



Attach gaskets and a spark plug sleeve adaptor to the cylinder head, and tighten four 5x12 bolts w/a sealing washer.

⚠ Caution: Apply the specified torque.

**Torque: 6 N · m (0.6 kgf · m)**

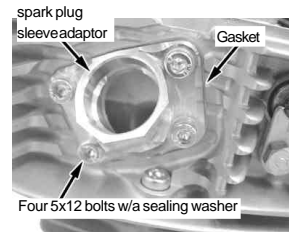

Attach an O-ring to the spark plug sleeve. Set the spark plug so its hex portion just fits into the grooves on the spark plug sleeve. And apply a thin coat of engine oil to the O-ring and the "Aluminum Special" slightly to the threaded portion on the spark plug.

Grooves on the spark plug sleeve

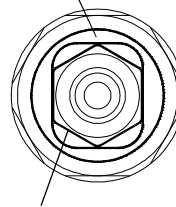

Hex portion of the spark plug

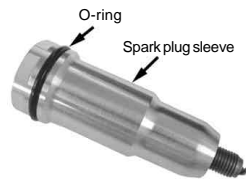

Attach a spark plug and spark plug sleeve to the cylinder head. Be careful not to jam the O-ring. First, screw the spark plug sleeve into the cylinder head with a hand by pulling it slightly, being careful that the spark plug is right on the groove of the spark plug sleeve. Install the spark plug sleeve onto the cylinder head by tightening it to the specified torque.

⚠ Caution: Apply the specified torque.

**Torque: 10 N · m (1.0 kgf · m)**

Do not overtighten the spark plug sleeve. Otherwise, the plug may be twis.



Now, you have completed the cylinder head installation.

Pour engine oil.  
Amount: 1.0 liter

10W - 40 ~ 15W - 50  
(Multigrade type)

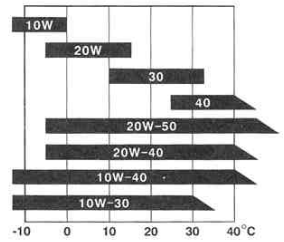

Referring to a genuine service manual, install the engine to the frame.

⚠ Caution: Be sure to follow the specified torque.

Install a carburetor, following the installation procedures of the carburetor kit.

⚠ Caution: Be sure to follow the specified torque.

Install a muffler, following the installation procedures of the exhaust muffler kit.

⚠ Caution: Be sure to follow the specified torque.

Install an ignition coil to the ignition coil stay with a 5x20 bolt.

⚠ Caution: Apply the specified torque.

**Torque: 6 N · m (0.6 kgf · m)**

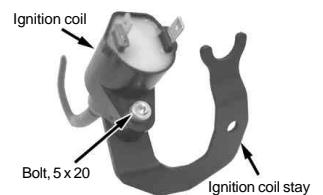

Install a distance collar into a hole at the bottom of the front part of the fuel tank to be mounted on the frame.

Decide at which rubber mounting portion of the fuel tank on the right side of the vehicle to install the ignition coil stay, and install the stay with a 6x65 flange bolt and a washer on the distance collar and with a flange nut and a washer on the left side of the vehicle.

**⚠ Caution:** Apply the specified torque.

**Torque: 10 N · m**  
**(1.0 kgf · m)**

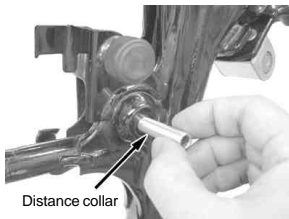

Decide where to set the fuel tank rubber as shown on the left

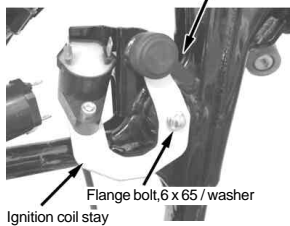

If the ignition coil and harness clamp interferes with each other, bent the harness clamp to avoid the protection.

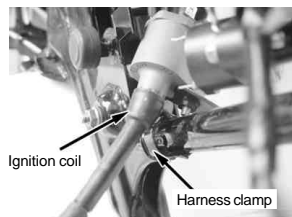

If you are using the ignition coil stay together with an oil cooler stay, be sure to install the ignition coil stay outside the oil cooler stay.

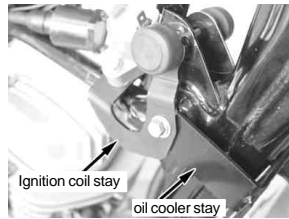

Connect the sub-cord to the wire harness and ignition coil.

Cut the high-tension cord on the subsidiary side of ignition coil to the proper length, and screw in and install the spark plug cap onto the high-tension cord.

Cut the high-tension cord at a point to keep it a little bit loose, with the plug cap and spark plug connected. Install the plug cap to the spark plug.



### Engine Starting

Check that the ignition key and the fuel cock are turned off.

Continue kicking the starter for a while to circulate the engine oil throughout the engine.

Apply "Aluminum Special", heat-resistant lubricating agent, a little to the threaded portion of the spark plug, and attach the spark plug and tighten it to the specified torque. Then attach a plug cap.

**⚠ Caution:** Apply the specified torque.

**Torque: 10 N · m**  
**(1.0 ~ 1.2 kgf · m)**



Please be sure to apply heatproof lubricant agent like "Aluminum Special" slightly to the threaded portion of a spark plug before tightening it, particularly when the spark plug is a new one.

Turn on the gasoline cock and the ignition key to start the engine.

**⚠ Warning:** Be sure to do the work in a well-ventilated place.

Check for abnormal sounds.

If no problem is detected, do running-in at least 100 to 150 km.

After the initial running-in, check for abnormality such as abnormal sounds or blow-by.

(If there is a problem, disassemble the engine again to check each part.)

**⚠ Warning:** Never reuse the pistonpin circlip.



# Twin Spark Super head+B ボアアップ 参照表 (115cc、120cc)

## Reference data on bore-up (115cc,120cc)

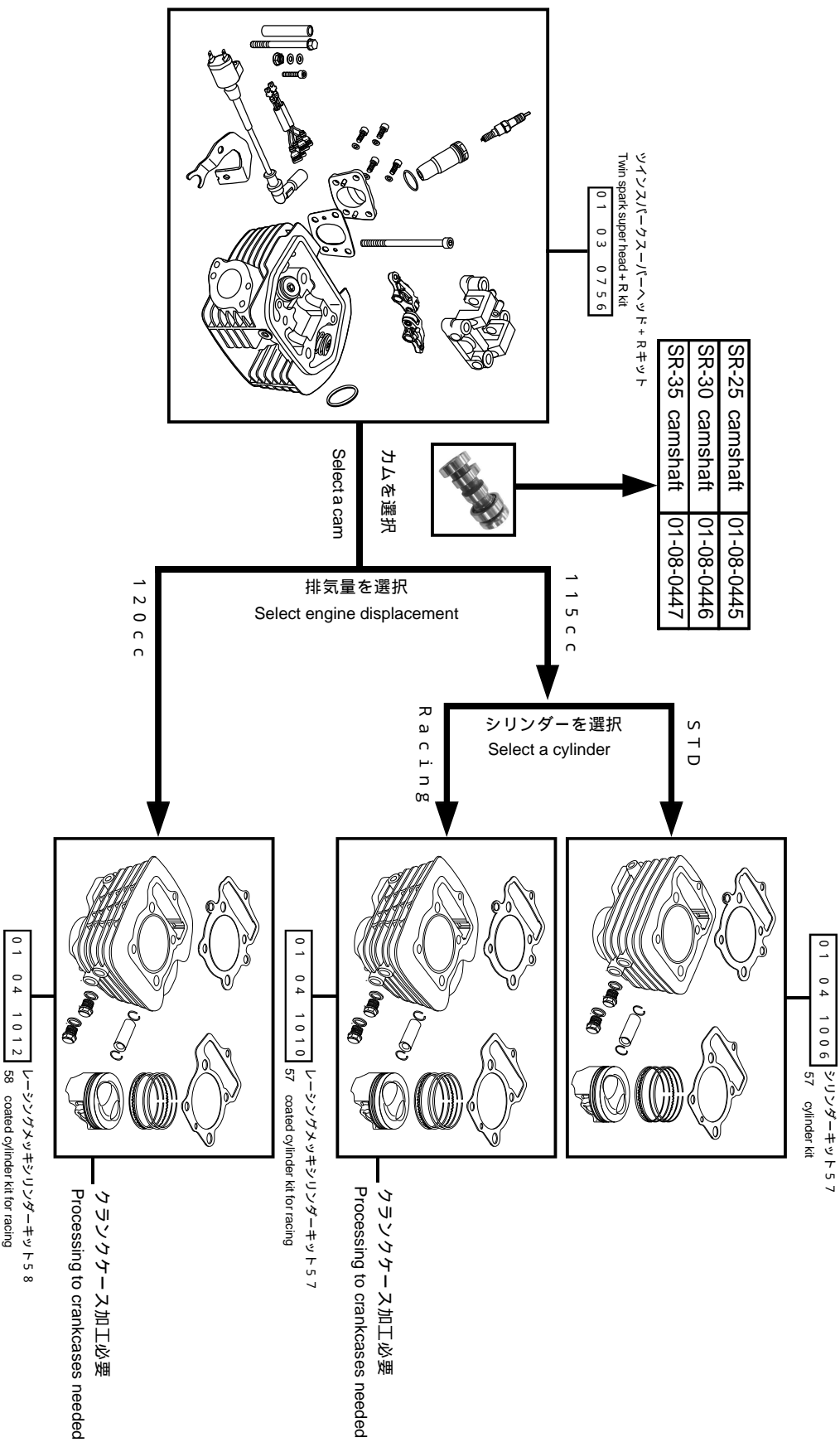

01 03 0756 シリンダーヘッドのみで購入された場合、この参照表にてボアアップパーツを検討して下さい。(ノーブルリンク使用時)  
 (Ape100: HC07 1600001~、Ape100 Type D: HC13 1000001~)  
 (ストローアップリンクを使用する際は各シリンダーキットは共通で使用出来ます。裏面のボアアップリンク参照表を参照下さい。)

If you have purchased a cylinder head alone (Item No. 01-03-0756), please study to purchase bore-up parts referring to this reference data.

(In the case of using a stock crankcase on Ape100: HC07-1600001~, Ape100 Type D: HC13-1000001~.)

( Even in case the stroke-up crank is used, these cylinder kits can be used. Please see the attached "Reference data on bore- & stroke-up kit." )



# Twin Spark Super head+B ボア&ストロークアップ参考表 (124cc、130cc)

## Reference data on bore- & stroke-up kit (124cc,130cc)

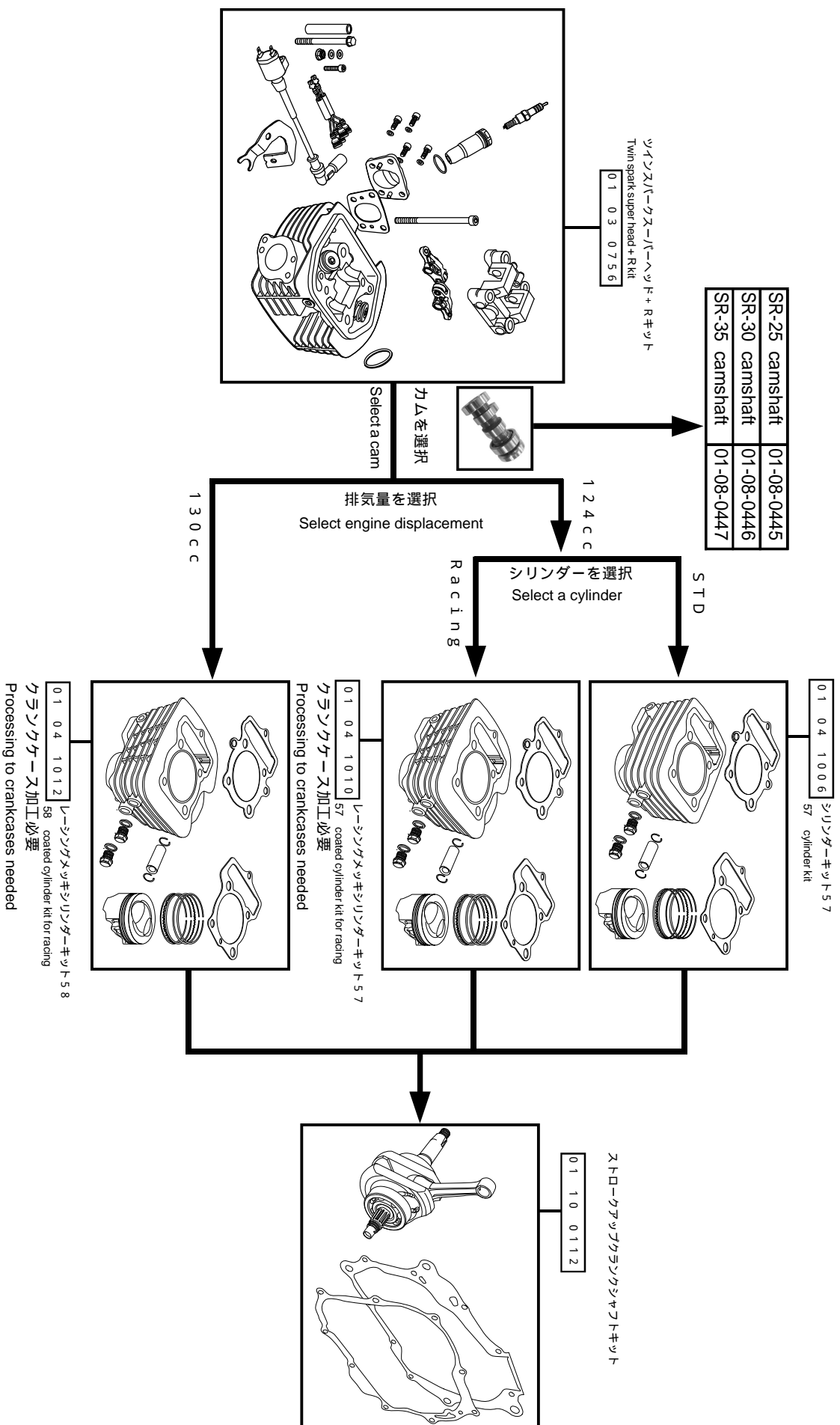

01 03 0756 シリンダーヘッドのみで購入された場合、この参照表にてボア&ストロークアップパーツを検討して下さい。  
If you have purchased a cylinder head alone (Item No. 01-03-0756), please study to purchase bore- and stroke-up parts referring to this reference data.  
(Ape100:HC07 1600001~、Ape100 Type D:HC13 1000001~)

# Twin Spark Super head+R ボアアップ 参照表 ( S C U T 1 2 5 c c 、 1 3 6 c c )

Reference data on bore-up (SCUT 125cc, 136cc)

SR-25 camshaft	01-08-0445
SR-30 camshaft	01-08-0446
SR-35 camshaft	01-08-0447

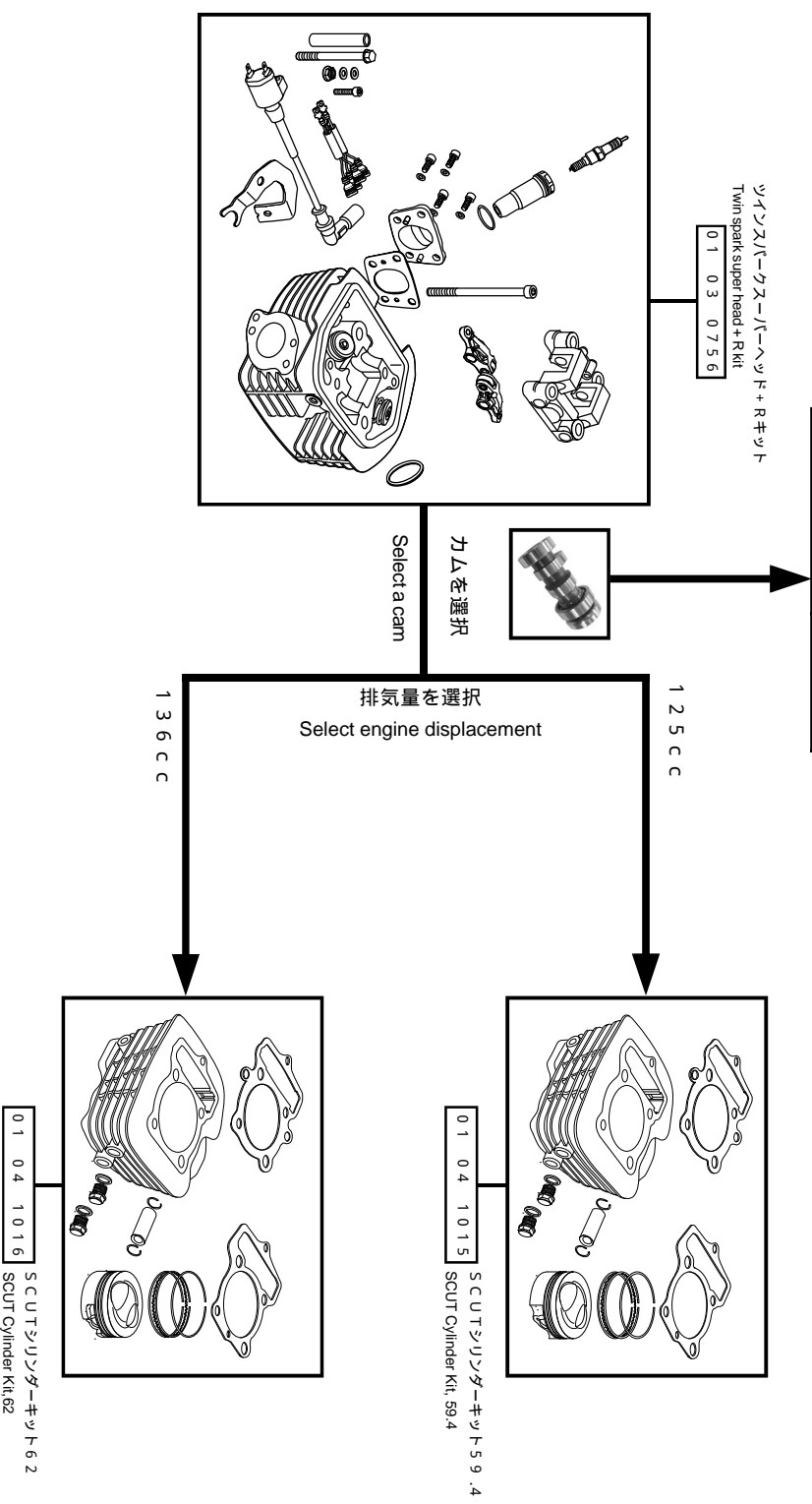

0 1 0 3 0 7 5 6 シリンダーヘッドのみで購入された場合、この参照表にてボアアップパーツを検討して下さい。(ノーブルクラック専用)  
 ( A p e 1 0 0 : H C 0 7 1 6 0 0 0 0 1 ~ 、 A p e 1 0 0 T y p e D : H C 1 3 1 0 0 0 0 0 1 ~ )

If you have purchased a cylinder head only of item No. 01-03-0756, please study to purchase parts for bore-up referring to this reference list.  
 (exclusively for a stock crank)

(In the case of using a stock crankcase on Ape100 : HC07-1600001 ~ , Ape100 Type D : HC13-1000001 ~ .)