



PAT No. 4203516  
US PAT. 7627949

# Instruction Manual for **SUPER HEAD 4VALVE / SCUT Cylinder Kit**

For exclusive use with Super Head 4VALVE

Item No. : 0 1 - 0 4 - 0 1 2 0 (178 cc)  
: 0 1 - 0 4 - 0 1 2 1 (178 cc, For Keihin FCRD28 / TDMR32 Carburetor.)  
Fits : KSR110 / KLX110

- Thank you for purchasing one of our products.
- This is a piston and cylinder kit for exclusive use with our Super Head 4VALVE. Please strictly follow the instructions to install and use the kit.
- This sleeveless cylinder, which is made of one-piece cast aluminum and ceramic chrome plated, has increased the durability and wear-resistance more than those of cast iron. The piston clearance is reduced so that the friction loss is decreased.  
The piston is designed to be lightweight and molybdenum coating is applied on the skirt portion in order to better break-in.
- The stick sensor can be installed on the cylinder. With the stick sensor and our optional thermometer, you can measure the temperature of cylinder.
- The cylinder is sleeveless and the skirt portion of piston is shortened in order that the piston moves only inside the cylinder even at BDC. So you can get the greater displacement of 178cc, over 138cc, without any modification of crankcase.
- 01-04-0121 is modified cylinder fin to fit Down draft carburetors (FCRD28/TDMR32).

**Please note: Illustrations and photos may vary from actual hardware.**

## ! Points to notice about sounds !

After installing this product, in some cases a cooling fin in the cylinder may resonate, making a sound. In this case, as a measure, fix a damper included in the kit to the cooling fin of the cylinder.

## Please read the following before installation.

We do not take any responsibility for any accident or damage whatsoever arising from the use of the products not in conformity with the instructions in the manual.

We shall be held free from any kind of warranty whatsoever of products other than this product if any defect takes place on the other products than this one after the installation and use of this product.

If you make modifications to the products, we shall be held free from any guarantee of the products.

This kit is for exclusive use with our Super Head 4VALVE.

Please be informed that we shall be held harmless against any claim against us whatsoever arising out of use of the products in racing and the like.

### ! Caution

The following show the envisioned possibility of injuries to human bodies or property damage as a result of disregarding the following cautions.

- This product is intended for use only in closed course racing or other off road competition and never on public roads or highways. Please drive safely and follow the local traffic laws.
- Work only when the engine and the exhaust system are cool to avoid burns.
- Prepare appropriate tools and work properly to avoid the breakage of parts or injuries.
- As some products and frames have sharp edges or protruding portions, work with your hands protected to avoid injuries.

### ! Warning

The following show the envisioned possibility of human death or serious injuries to human bodies as a result of disregarding the following cautions.

- Those who are technically unskilled or inexperienced are required not to do the work.  
(Improper installation because of insufficient skill and knowledge could lead to parts breakage and subsequently to accidents.)
- Always use new piston pin circlips, gaskets, seals and the like. Worn or damaged ones may cause accidents because of breakage of these parts.
- Before working place the motorcycle on level ground to stabilize its position for safety to avoid the motorcycle overturning.
- If you find damaged parts when inspecting or performing maintenance of your motorcycle, do not use these parts, and replace them with new ones.  
(The continued use of these damaged parts could lead to accidents.)
- Always start the engine in a well-ventilated place, and do not turn on the engine in an airtight place.  
(Otherwise, you will suffer from carbon monoxide poisoning.)
- Before riding, always check such parts as screws for loose. If you find loose ones, screw them securely up to the specified torque to avoid parts coming off.
- When you notice something abnormal with your motorcycle, stop riding immediately and park your motorcycle in a safe place to avoid an accident.
- As gasoline is highly flammable, never place it close to fire. Make sure that nothing flammable is near the gasoline. (It may cause a fire.)
- Check or perform maintenance of parts correctly according to the procedures in the instruction manual or a service manual.  
(Improper checking or maintenance could lead to accidents.)
- Never use parts other than those specified by us. (Or, the unspecified parts may break, leading to accidents.)
- Always use a torque wrench to tighten bolts and nuts securely to the specified torque to avoid these parts getting damaged or loose.
- Since vaporized accumulation of gasoline is quite dangerous, work in a well-ventilated place. (It is at the high risk of explosion.)
- Be sure to always use premium unleaded petrol. (Otherwise, troubles such as knocking of an engine may cause accidents.)

Please be informed that the product specifications, design and prices are subject to change without prior notice.

Please be informed that we do not accept any complaint filed with us against any technical trouble caused by the combined use of our products with other manufacturers' products unspecified by us.

Please retain this Instruction Manual for future reference.

~ Kit Contents ~

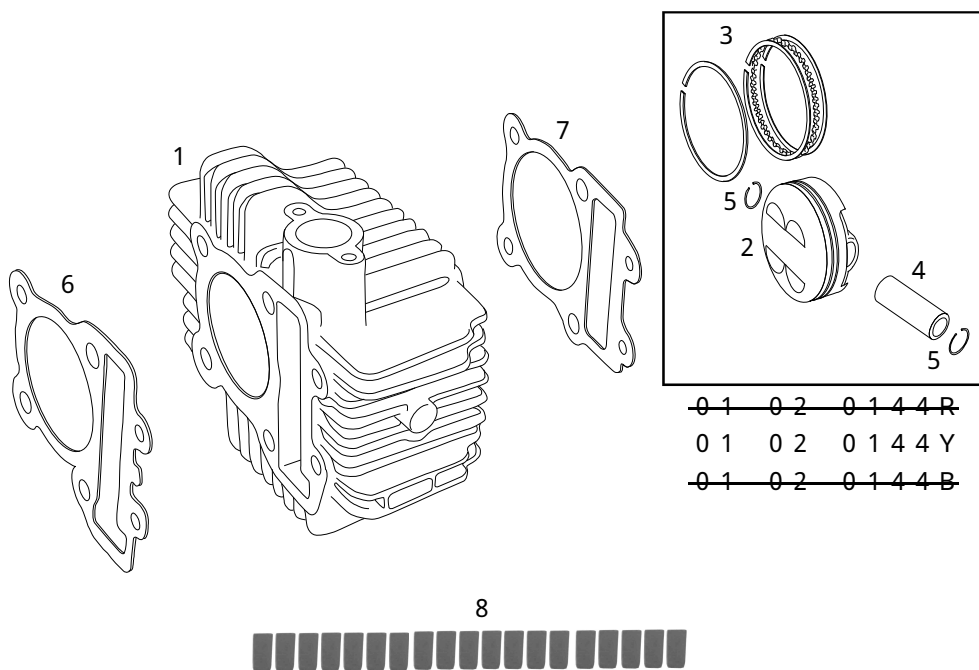

~~01 02 0144R~~  
 01 02 0144Y  
~~01 02 0144B~~

No.	Part Name	Qty	Repair Parts Item No.	In packs of
1	Cylinder	1	_____	_____
2	Piston	1	<del>#13101-KFS-T00R-</del>	1
			#13101-KFS-T00Y	1
			<del>#13101-KFS-T00B-</del>	1
3	Piston ring set (top, oil)	1	13011-KSS-T00	1
4	Piston pin	1	13112-165-T02	1
5	Piston pin circlips	2	00-01-0003	6
6	Cylinder head gasket	1	01-13-0109	1
7	Cylinder gasket	1		
8	Cylinder dampers B	29	00-01-0031	10

# There are three sizes of replacement pistons. As the clearance of the pistons in this kit is severe, you need to carefully inspect the cylinder size to fit.

When you order piston, please place an order with the Repair Parts Item No. referring to the owner's manual.

Please order repair parts with the Repair Part Item No. Without the repair part item No., we may not be able to provide the correct parts.

Some parts are only available as a set. Please order them with the set number.

\_\_\_\_\_ discontinued product

Benchmark data

Bore & stroke	Displacement	Compression ratio
67 x 50.6	178.3 cm <sup>3</sup>	12.0:1

**SPECIAL PARTS TAKEGAWA** Co.,Ltd.

3-5-16 Nishikiorihigashi Tondabayashi Osaka Japan

TEL : 81-721-25-1357 FAX : 81-721-24-5059

URL : <http://www.takegawa.co.jp>

## ~ Installation Procedures ~

- ⚠ **Caution: Always be sure to tighten parts to the specified torque using a torque wrench.**
- ⚠ **Notice: The unskilled or those without proper knowledge are requested not to do the installation work.**

Installation of this kit requires, in some cases, engine removal and crankcase disassembly. Please prepare and refer to a genuine service manual to do the proper installation work.

According to the service manual, demount the engine from the frame and and disassemble it.

A crankcase may interfere with a cylinder sleeve depending on individual differences of the crankcases. If there is interference, the crankcase needs processing.

Setting the cylinder in place with a dowel pin, attach it to the crankcase, and check for the interference with the crank cases.

In case there is interference, see where the cylinder interferes with the crankcases.

Referring to the service manual, disassemble the crankcases, and scrape the interfering part with a file or a hand grinder but bit by bit not to over-scrape the portion.

In scraping, be careful not to let the cutting chips and shavings into bearings and other parts. After the processing of the crankcases, clean them.

After disassembling the crankcases, check every component referring to the service manual.

⚠ **Caution: Do inspection of every component and replacement of consumables, with utmost care.**

### Inspection of Crank Shaft

- Measure the internal diameter at the small end of the con'rod.  
If larger than 13.05 mm, replace it.
- Measure the clearance at the big end of the con'rod in the axial direction.  
If larger than 0.4mm, replace it.

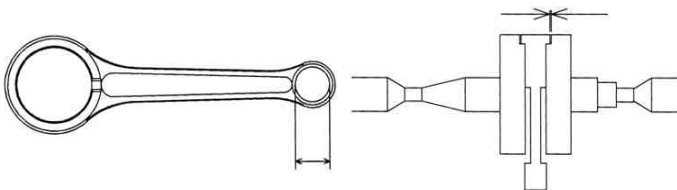

- Measure the misalignment at two points at the big end of the con'rod at right angles to the shaft as shown in the figure on the right.  
If larger than 0.07mm, replace it.

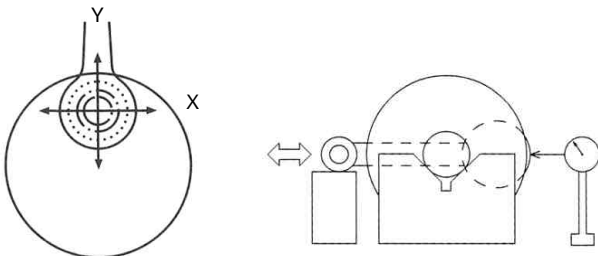

- Measure the misalignment on the journal bearing of the crank shaft.  
Shaft direction: If larger than 0.10 mm, replace it.  
Bearing direction: If larger than 0.05 mm, replace it.

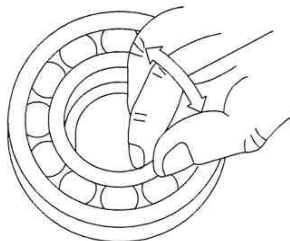

- Measure the deflection of the crank shaft.  
If larger than 0.08 mm, replace it.

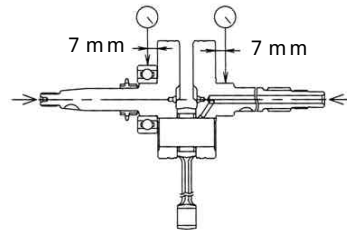

- o Assemble the crankcase referring to the service manual.

## ~ Cylinder Installation Procedures ~

When use on non-modified cylinder.

Need to be cut about 10mm tip of the fin. (as shown)

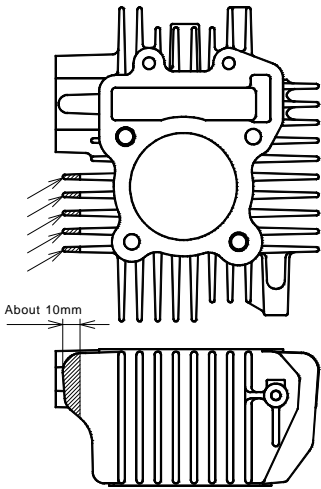

Please cut only as need to fit carburetor.

Securely fix cylinder dampers B, included in the kit, between the cylinder cooling fins until they hit a dead end as shown in the figure below.

(This installation is aimed at reducing a resonant sound from a cylinder cooling fin.)

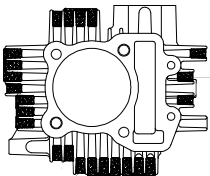

Install the dampers between the fins

Attach a piston pin circlip to one of two pin holes on the piston.



Attach the piston pin circlip so the ring end gap does not meet with the notch on the piston pin hole, and it should be either on the top or at the bottom of the piston as illustrated in the fig. 1 below.



Notch

Air-blow the piston rings and the piston pin, and check for jamming of any foreign material by these parts. Apply engine oil to grooves for piston rings, and, with reference to the figure below, fix piston rings and arrange the location of piston ring end gaps.

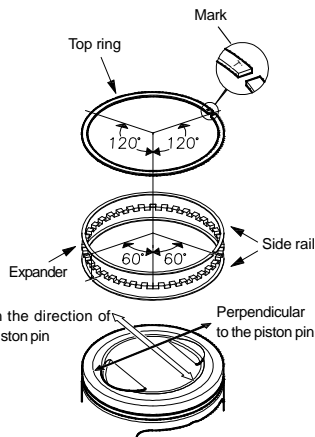

Apply molybdenum solution to the piston pin and the holes on the connecting rod small end.



Attach the piston to the connecting rod with an arrow on the piston in the direction of the exhaust side.



Plug the sleeve hole and the cam chain hole on the crank case with a clean cloth, and fix a piston pin circlip.



Remove the cloth used to plug holes. Thoroughly degrease the cylinder base of the crankcase, and fit a dowel pin into the dowel pin hole.



Fix a cylinder gasket of the kit into the cylinder base of the crankcase.

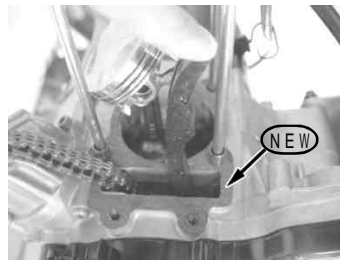

Apply engine oil to the entire inner surface of the aluminum cylinder bore.



Put the aluminum cylinder into the stud bolt, and attach the cylinder, compressing the piston rings. Be careful not to move the piston ring gaps out of position.

⚠ Caution: Do the work with care not to damage the piston rings.



Attach the cam chain guide to the cylinder.

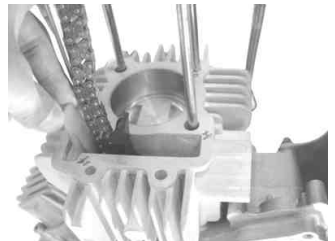

Installing the chain guide on cylinder, the chain guide may not reach at the bottom of the groove. In that case, you need a modification as the photo shown below to install the chain guide properly.

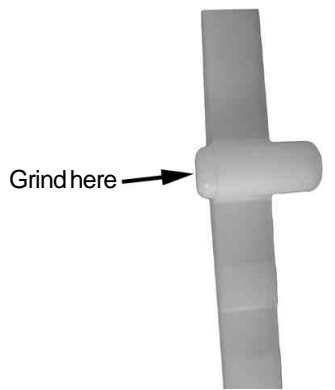

Install the cylinder head with reference to the instruction manual.

# INSPECTION / SERVICE LIMITS

## ⚠ WARNING

Since this cylinder manual is prepared for those who have acquired basic skills and knowledge in tuning, those who are technically unskilled or inexperienced are required not to do the work.

### Reference Value List for Cylinder Maintenance

Item		Stock	Service limit	Remarks
Cylinder	Distortion	_____	0.05 mm	Replace
	Internal diameter	_____	67.04mm	Replace
Piston	External diamter ( 3.5 mm from the hem of a skirt)	_____	66.95mm	Replace
	Internal diameter of a pin hole	_____	13.03 mm	Replace
External diameter of a piston pin		12.994 ~ 13.000 mm	12.98 mm	Replace
Piston ring end gap size		_____	0.50 mm	Replace
			0.90 mm	Replace
Clearance between cylinder and piston		0.005 ~ 0.012 mm	0.05 mm	Replace
Clearance between piston and pin		0.002 ~ 0.014 mm	0.05 mm	Replace

Torque unit

1 kgf · m = 9.80665 N · m (=newton meter)

**(M0-OIL)**

This mark shows molybdenum solution.

This solution is a mixture of molybdenum grease and engine oil (in the ratio of 1:1).

Apply molybdenum solution or assembly paste to the portions where it is indicated that molybdenum solution needs to be applied.

**(NEW)**

This mark shows those parts to be replaced with every overhaul.

Do not fail to replace these parts every time they are overhauled.

**(OIL)**

Engine oil mark

Apply engine oil where so indicated.

# INSPECTION / SERVICE LIMITS

## Inspection of Cylinder

- Check the inside of cylinder for wear and damage.
- Measure the internal diameters of the cylinder bore at 6 positions; at the piston pin angle and at the right angle to it (X-Y) each at upper, middle and lower parts of the cylinder bore.

Treat the largest value as its internal diameter.

If larger than 67.04mm, replace it.

Calculate the clearance between a cylinder and a piston.

Check that the clearance is within the standard value specified in the specification list.

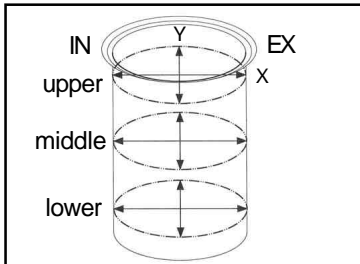

Cylinder wall

	Piston part number
66.986 ~ 67.000	13101-KFS-T00R (Red paint)
67.001 ~ 67.014	13101-KFS-T00Y (Yellow paint)
67.015 ~ 67.030	13101-KFS-T00B (Blue paint)

In case the cylinder wall is beyond the service limits, change the cylinder and piston at the same time as a set.

— discontinued product

- Check the top surface of the cylinder for scratches and damages.
- Check the cylinder top surface for distortion with a straight edge and thickness gauge.

Service limit: If the distortion is more than 0.05 mm, replace the cylinder.

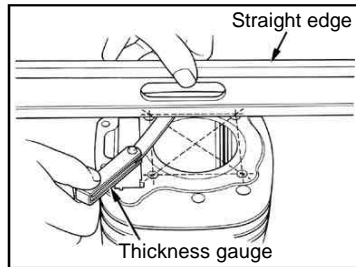

## Inspection of Piston

- Clear the piston of the remaining carbon residue.
- Fit a piston ring into the piston, and measure the clearance between the piston ring and ring groove with a thickness gauge.

Service limit : 0.17mm.

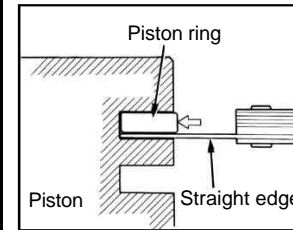

- Check the piston for damages.
- Measure the external diameter of the piston at the specified place at the bottom edge of the piston skirt at the right angle to the piston holes.

Service limit : 66.95mm.

Figure out the clearance between cylinder and piston.

Inspect that the clearance is within the standard value specified in the specification list.

If not, change the piston with a new one.

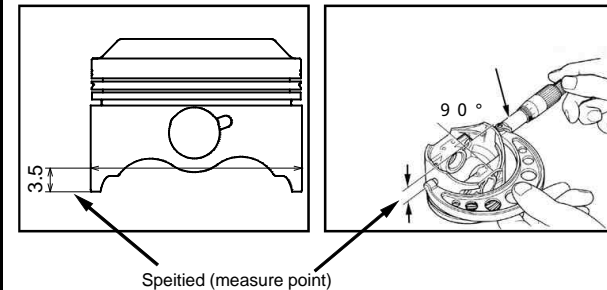

# INSPECTION / SERVICE LIMITS

- Measure the internal diameter of the piston pin hole.  
If larger than 13.03mm, replace it.



- Measure the external diameter of the piston pin.  
Piston pin service limit : If it is below 12.98 mm,  
replace the piston pin.

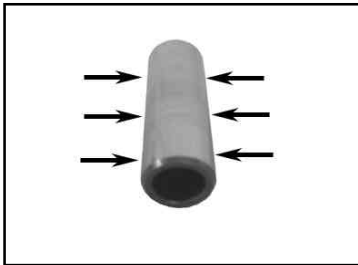

- Calculate the clearance between the piston and the piston pin.

## Inspection of Piston Ring

- Press down a piston ring into the piston with the piston head, and measure the clearance of the ring-end gap at the horizontal position with a thickness gauge.  
Top : If larger than 0.5mm, replace them.  
Oil : If larger than 0.9mm, replace it.

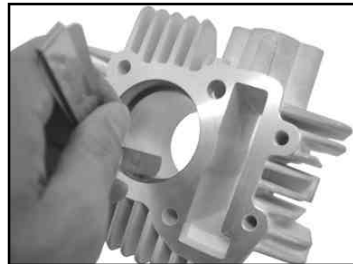

## Supplement:

- A number and an alphabet are stamped on the top and side of the cylinder respectively. In case you cannot measure the cylinder wall, you can designate the type of the cylinder and order it by the stamped numbers. This is limited only to the case where there is no damage or scratch on the cylinder wall.

### In case you judge by the piston:

- After removing the carbon stuck on the piston top, take a note of the No. stamped on the piston top.

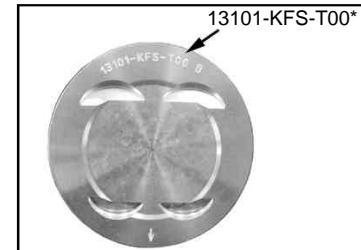

- Order the piston by the No. stamped on the piston top.

### In case you judge by the cylinder:

- Take a note of the No. stamped on the side of the cylinder.

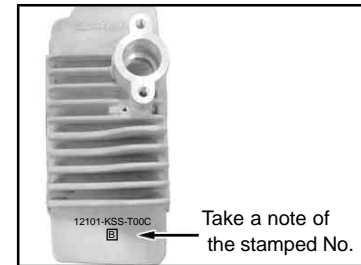

	Piston part number
When an R is stamped	13101-KFS-T00R (Red paint)
When a Y is stamped	13101-KFS-T00Y (Yellow paint)
When a B is stamped	13101-KFS-T00B (Blue paint)

### In case No. is not stamped on the cylinder:

- Measure the cylinder by the inspection method described on page C2, and replace the piston with the one with a specified piston part number.

— discontinued product