

SuperHead 4-Valve+R Bore Up Kit 106cc

(SCUT Cylinder • 10/15D Cam shaft)

Product number 01-05-8051

Adaptation model	12V Monkey & Gorilla (Z50J-2000001 ~)
	(AB27-1000001 ~ 1899999)
	Monkey R (AB22-1000017 ~)
Monkey RT (AB22-1007601 ~)	

- We are flattered that you have purchased one of our products. Please strictly follow the instructions in installing and using the products.
- This is a Super head 4 VALVE + R / bore up (57x41.4 105.6cc) kit for the Monkey and Gorilla. The use of a SCUT Cylinder kit soups up the engine to 106 cc without change the crankshaft. This product, with a camshaft equipped with an automatic decompression function, is so designed that the engine can start easily.
- Before install the products, please be sure to check the contents of the kit. Should you have any questions about the products, please kindly contact your dealer.

© If the description, such as photos or Illustration different with this part.

~ Kit Contents ~

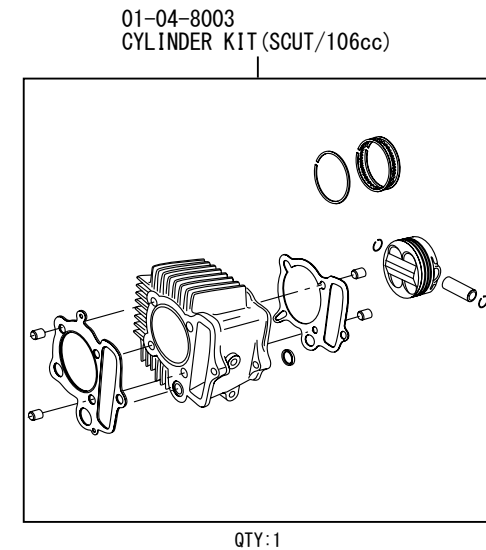
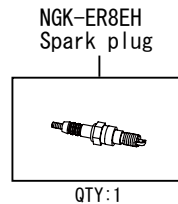
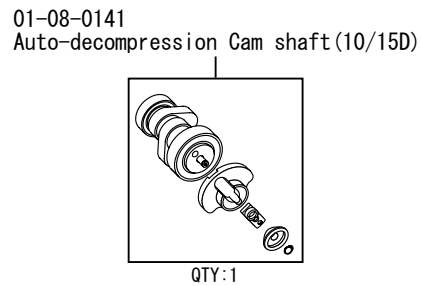
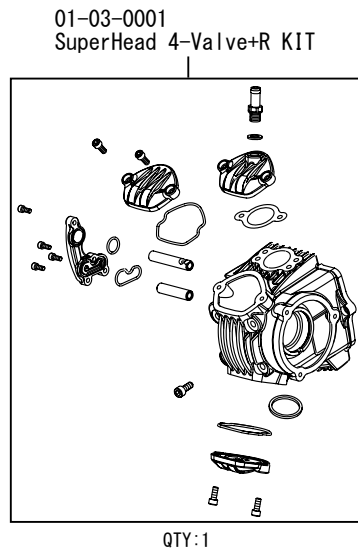

☆ Please read carefully before use ☆

- © This product is designed for exclusive use on the closed course.
- © We do not take any responsibility for any accident or damage whatsoever arising from the use of the products not in conformity with the instructions in the manual.
- © This kit is designed for exclusive use in the above-mentioned applicable models and frame numbers only. Please take note that this kit cannot be mounted on other models of motorcycles.
- © Please be informed that, mainly because of improvement in performance, design changes, and cost increase, the product specifications and prices are subject to change without prior notice.

SPECIAL PARTS
TAKEGAWA

CONTACT Address : 3-5-16 Nishikiorihigashi Tondabayashi Osaka JAPAN
TEL: +81-721-25-1357 FAX:+81-721-24-5059 e-mail:english@takegawa.co.jp URL <http://www.takegawa.co.jp>
Please contact with your name and country name provided. (Only English please)