



SUPER HEAD 4VALVE Combo Kit 138cc

Item No. : 01 - 05 8829
Applicable models and frame No.
KLX110L : LX110D-A72046 ~

- Thank you for purchasing one of our products. Please strictly follow the instructions in installing and using the kit.
 - This product comprises kits for bore-up (59x50.6 138.3cc) for SSuper head 4VALVE for the KLX110L, and a VM26 carburetor.
- Before installing the kit, please be sure to check the kit contents. Should you have any questions about the kit, please contact your local TAKEGAWA dealer.

Please note: Illustrations and photos may vary from actual hardware.

~ Kit Contents ~

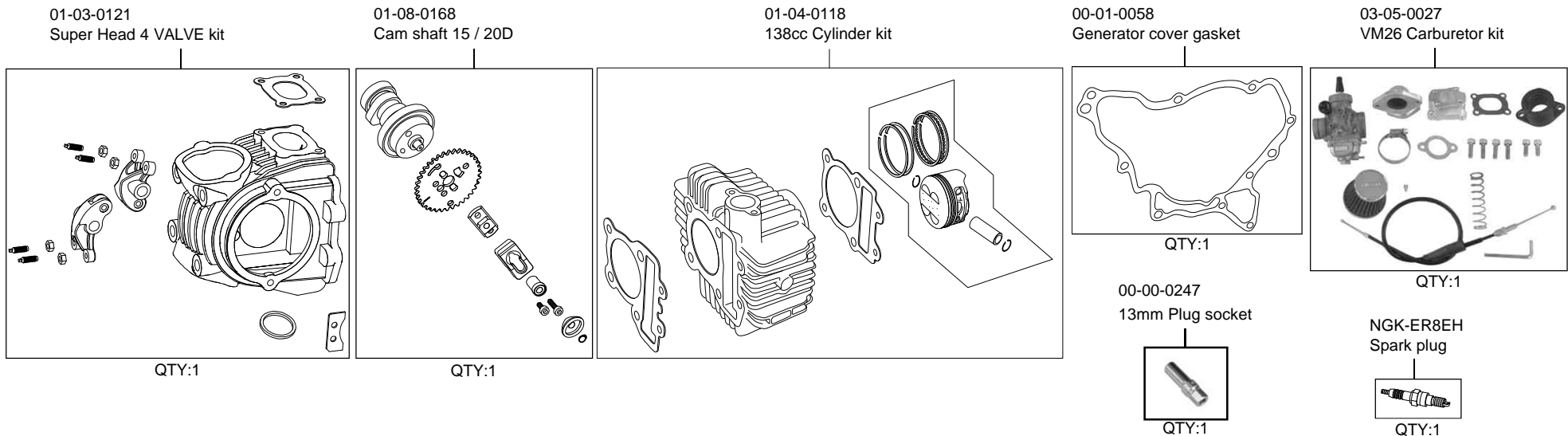

Please read the following before starting the installation

This kit is designed for exclusive use for the closed racing. So never use this kit for running on a public road.
We do not take any responsibility for any accident or damage whatsoever arising from the use of this kit not in conformity with the instructions in the manual.
This kit is designed for exclusive use in the above-mentioned applicable models with the specified frame numbers only. Please take note that this kit cannot be mounted on other types of motorcycles.
Please be informed that, mainly because of improvement in performance, design changes, and cost increase, the product specifications and prices are subject to change without prior notice.

SPECIAL PARTS TAKEGAWA Co.,Ltd.
3-5-16 Nishikiorihigashi Tondabayashi Osaka Japan
TEL : 81-721-25-1357 FAX : 81-721-24-5059 URL : <http://www.takegawa.co.jp>