



# *Twin Spark Super head+R* Racing Bore and Stroke Up Kit, 146cc

- Thank you for purchasing one of our products. Please strictly follow the following instructions in installing and using the kit.
- This is a 146cc Racing Bore and Stroke Up Kit (62x48.5) for Twin Spark Super Head+R.  
Before assemble the kit, please be sure to check the kit contents. It is strongly requested that you strictly follow the instructions for each kit. Should you have any questions about the kit, please contact your local TAKEGAWA dealer.

Please note that, in some cases, the illustrations and photos may vary from the actual hardware.

Item No. : 01 - 06 0007

Compatible models and the frame No.:

Ape100 : HC07-1600001 ~

Ape100 Type D : HC13-1000001 ~

(All models need to be equipped with a secondary air supply system.)

## ~ Kit Contents ~

01-03-0756  
Twin Spark Super Head +R kit

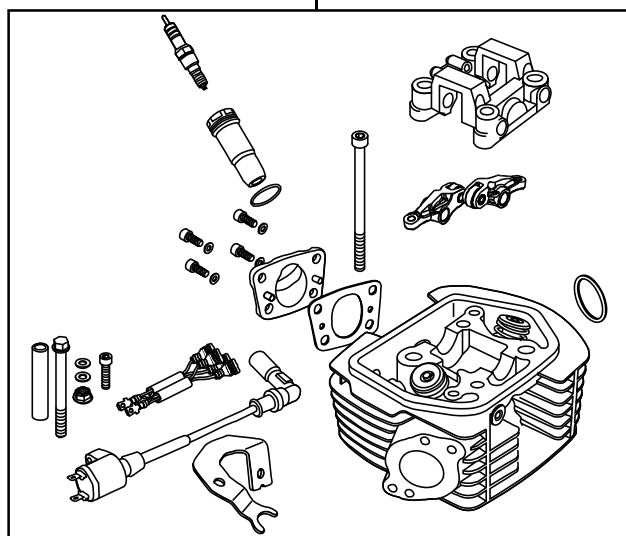

QTY : 1

01-08-0446  
SR-30 Camshaft



QTY : 1

01-04-1017  
62 SCUT Plated Cylinder kit

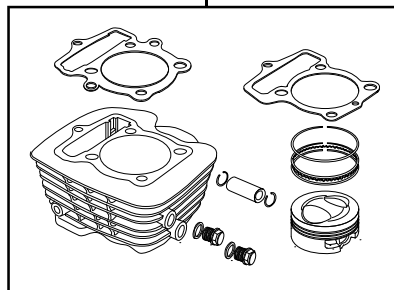

QTY : 1

01-10-0117  
Stroke-up Crank Kit (146cc / 48.5-stroke)  
for only 146cc kit

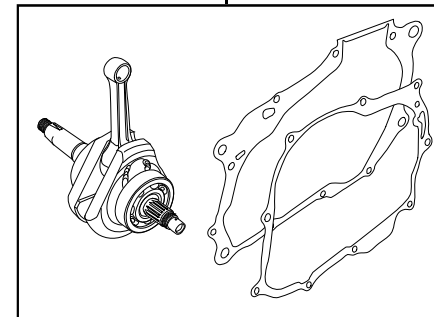

QTY : 1

## Read all instructions first before starting the installation

This kit is intended for closed course competition purposes only.

We do not take any responsibility for any accident or damage whatsoever arising from the use of the kit not in conformity with the instructions in the manual.

Please note that this kit is designed for exclusive use in the above-mentioned compatible models and frame numbers only and that it cannot be mounted on other models.

Please be informed that, mainly because of improvement in performance, design changes, and cost increase, the product specifications and prices are subject to change without prior notice.

**SPECIAL PARTS TAKEGAWA** Co.,Ltd.

3-5-16 Nishikiorihigashi Tondabayashi Osaka Japan TEL:81-721-25-1357 FAX:81-721-24-5059 URL: <http://www.takegawa.co.jp>