

SuperHead+R Bore- & Stroke-up kit, 124cc

Product number 01-06-0028

Adaptation model	Ape100	(HC07-1000001 ~) (HC13-1000001 ~)
	XR100 Motard	(HD13-1000001 ~)
	XR100R	(HE03-2100001 ~)
	CRF100F	(HE03-2400001 ~)

- Thank you for purchasing one of our products. Please strictly follow the following instructions in installing and using the kit.
- This product is a kit for bore- and stroke-up (57x48.5 124cc) for Super Head+R.
- Before assemble the kit, please be sure to check the contents. Should you have any questions about the products, please kindly contact your local TAKEGAWA dealer.

© Please note that, in some cases, the illustrations and photos may vary from the actual hardware.

~ Kit Contents ~

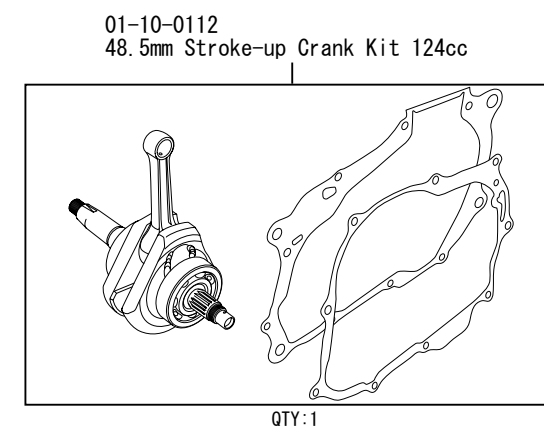
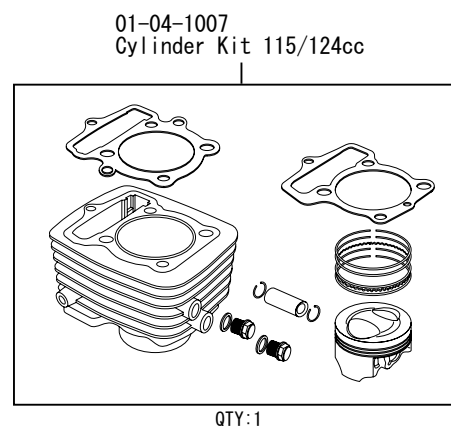
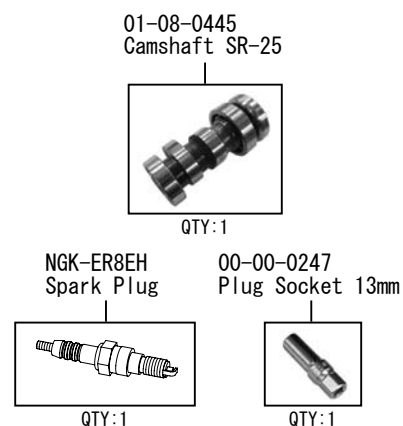
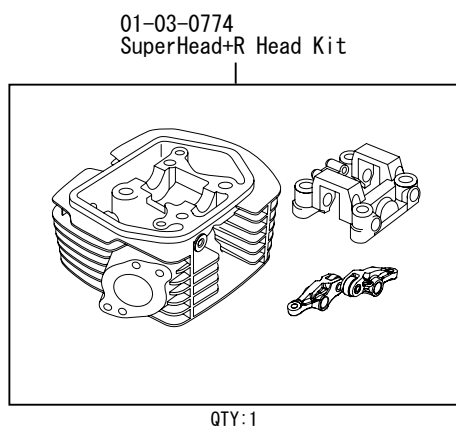

☆ Please read carefully before use ☆

- © This product is designed for exclusive use on the closed course.
- © The use ignoring the instructions that are written in the manual, if the accident or damage has occurred, we can not assume any responsibility for compensation.
- © This product is the above-mentioned vehicle exclusive goods. Is not possible attached to the other vehicle. Please note.
- © Please note. Performance up, the design change, the product and the price in the cost up, etc. are subject to change without notice.
- © Please be informed that we shall be held harmless against any claim against us whatsoever arising out of use of the products in racing and the like.

SPECIAL PARTS
TAKEGAWA

CONTACT Address : 3-5-16 Nishikiorihigashi Tondabayashi Osaka JAPAN
TEL : +81-721-25-1357 FAX : +81-721-24-5059
e-mail : english@takegawa.co.jp URL http://www.takegawa.co.jp
Please contact with your name and country name provided. (Only English please)