



DOHC Bore Stroke Up Kit SCUT 125cc

Item No. : 01 - 06 - 6012

Compatible Models and Frame No.:

12V Monkey & Gorilla : Z50J -2000001 ~

: AB27-1000001 ~ 1899999

Monkey BAJA : Z50J -1700001 ~

Monkey R / RT : AB22-1000017 ~

- Thank you for purchasing one of our products. Please strictly follow the following instructions in installing and using the kit.
- This is a kit for 125cc Bore and Stroke Up (57 x 48.9) with DOHC, for the Monkey and Gorilla. SCUT method possible enlarges displacement to 125cc without boring crankcase. Before installing the kit, please be sure to check the kit contents. Should you have any questions about the kit, please contact your local motorcycle dealer.

Please note that, in some cases, the illustrations and photos may vary from the actual hardware.

~ Kit Contents ~

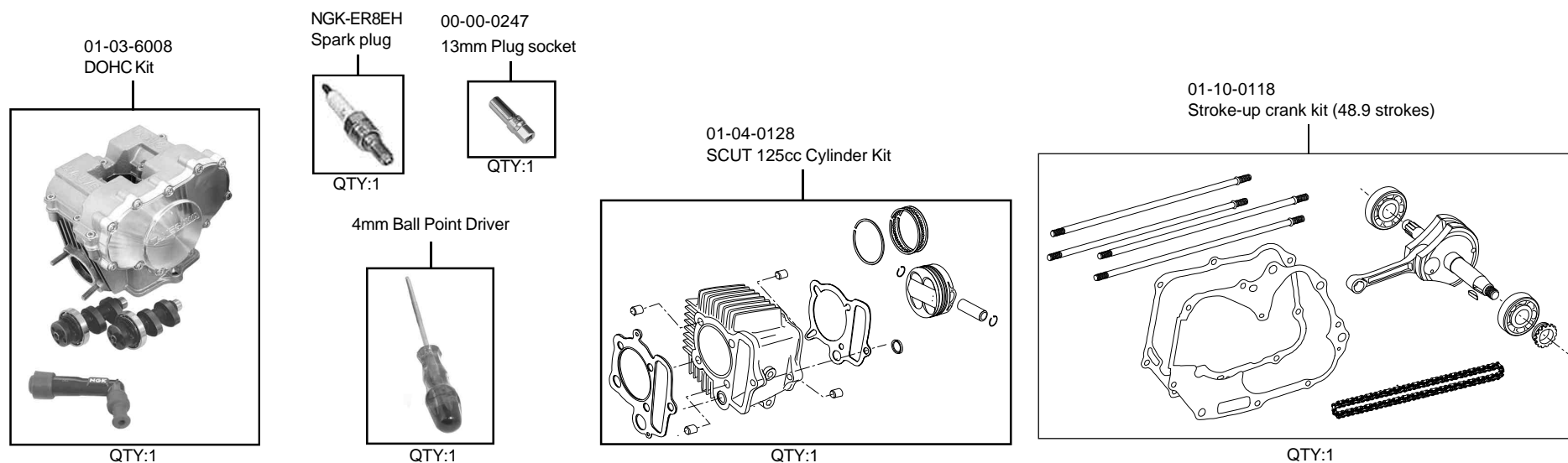

Read all instructions first before starting the installation

This kit is intended for closed course competition purposes only. So, take note that it is prohibited to drive your motorcycle on a public road after the installation of this kit. Drive your motorcycle at a legal speed, abiding by the laws.

We do not take any responsibility for any accident or damage whatsoever arising from the use of the kit not in conformity with the instructions in the manual.

Please note that this kit is designed for exclusive use in the above-mentioned compatible models and frame numbers only and that it cannot be mounted on other models.

Please be informed that, mainly because of improvement in performance, design changes, and cost increase, the product specifications and prices are subject to change without prior notice.

Due to high power engine, we recommend to use our Special HD crankcase Kit 01-10-0042.

SPECIAL PARTS TAKEGAWA Co.,Ltd.

3-5-16 Nishikiorihigashi Tondabayashi Osaka Japan TEL:81-721-25-1357 FAX:81-721-24-5059 URL: <http://www.takegawa.co.jp>