

Special Clutch Kit Instruction Manual

(For use with Aluminum die-cast cover, buffed & clear painted /
for exclusive use with 3 speed close-ratio gear or 4 speed close -ratio transmission.)

Item No. 02-01-0098

Fits	XR50R (AE03-1000001 ~)
	XR70R (DE02-1000001 ~)
	CRF50F (AE03-1400001 ~)
	CRF70F (DE02-1700001 ~)

Thank you for purchasing one of our products. Please strictly follow the following instructions in installing and using the Kit.
Before installing the Kit, please be sure to check the Kit contents.
Should you have any questions about the Kit, please contact your local motorcycle dealer.

◎ Please note that the descriptions in this manual like illustrations and photos may differ from the actual hardware.

☆ Read all instructions first before starting the installation ☆

◎ We do not take any responsibility for any accident or damage whatsoever arising from the use of the product not in conformity with the instructions in this Instruction Manual.

◎ You are requested not to contact us about the combination of our product with other manufacturers'.

◎ Please note that this Kit is designed for exclusive use in the above-mentioned compatible models and frame numbers only and that it cannot be mounted on any other models.

◎ Those who are technically unskilled or inexperienced are required not to do the work. (Improper installation because of insufficient skill or knowledge could lead to parts breakage.)

◎ This kit combines an aluminum diecast cover kit and a special clutch kit (slipper).

For installation, please refer to instruction manuals for relative products.

◎ Please be informed that, mainly because of improvement in performance, design changes, and cost increase, the product specifications and prices are subject to change without prior notice.

◎ This manual should be retained for future reference.

~ Important Notice ~

- In installing this kit, one of our original transmissions is required.
- An optional clutch lever that fits your handle bar in size is required.

Kit includes

02-01-5106

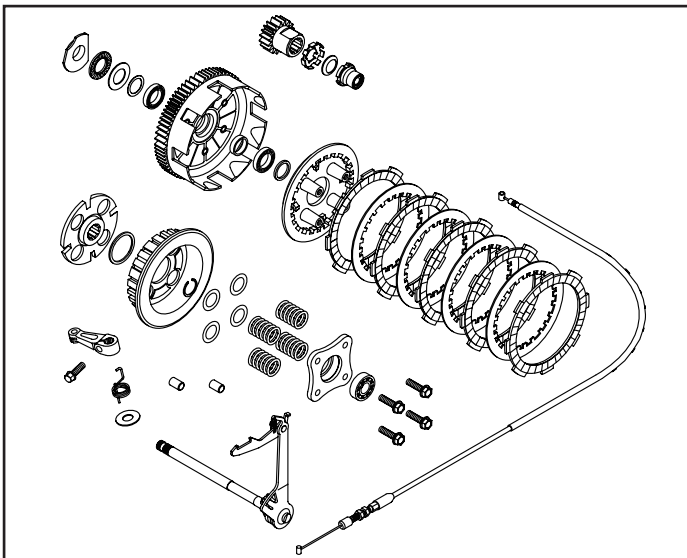

02-01-5024

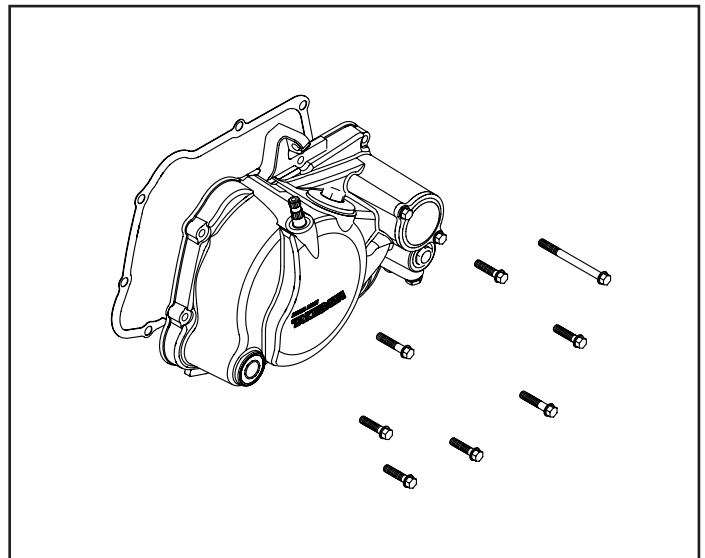

Item No.	Part Name	Qty
02-01-5024	Special Clutch Cover Kit	1
02-01-5106	Special Clutch Kit (slipper)	1