

# Special Clutch Cover Kit (Wire type) Instruction manual

Product number 02-01-0150

Adaptation model	GROM : JC61-1000001 ~ 1299999
	: JC61-1300001 ~
	: JC75-1000001 ~
	MSX125
	MSX125SF

Thank you very much for purchasing our products.

Thank you so you will comply with the following matters at the time of use. Before installation, please check your always kit contents. If there is a point of notice event, Please contact us the dealer of purchase.

◎ If the description, such as photos or illustration different with this part.

☆ Please read carefully before use ☆

◎ The use ignoring the instructions that are written in the manual, if the accident or damage has occurred, we can not assume any responsibility for compensation.

◎ This product installation and use, when a problem occurs to after market goods, guarantee other than this product, also can not assume any in any such matters.

◎ If it was the case or mounting that has been processed like a product, it will not be covered under warranty.

◎ It is not possible to inquire of the combination of other manufacturers.

◎ This product is the above-mentioned vehicle exclusive goods. Is not possible attached to the other vehicle. Please note.

◎ Please refer to the genuine service manual for the above-mentioned compatible models for the assembly work.

◎ Special tools are required to install this product. Please prepare separately.

Lock nut wrench : 07916-6390001 (Genuine Honda tool) or Lock nut wrench : 00-01-0152 (Takekawa tool)

Gear holder : 07724-0010100 (Genuine Honda tool) or Universal holder : 00-01-1002 (Takekawa tool)

~ feature ~

• Rack & pinion wire clutch cover that enables light and smooth operation.

• R.Crankcase cover is made of die-cast aluminum with black paint, and clutch cover is made of forged aluminum with shot blast.

• By adopting a paper cartridge oil element, the centrifugal oil filter can be removed and reducing the load on the crankshaft and improving engine response.

• Thermostat unit (02-01-5052: optional) can be installed. Thermostat prevents overcooling with oil cooler.

• The oil level window makes it easy to check the oil level.

• Filtered oil flows through the oil element by two passage (crankshaft / transmission) with this kit.

(In the stock clutch cover, only one crankshaft passage passes through the centrifugal filter from oil pump.)

※ By connecting our bore-up cylinder (oil outlet equipped model) and oil line hose kit (00-07-0095: optional), the oil through the oil element can flow to the cylinder head.

• Clutch cover for stock clutch or Takekawa slipper clutch.

In addition, it is possible to upgrade to a clutch cover that supports heavy duty clutches (wet or dry) by installing optional items.

**! Caution** When the handling of ignoring this display, property damage and human shows the assumption of what injury.

■ On the street, keep the legal speed and obey the traffic law.

(If you drive faster than the legal speed, you will be punished for violating the Road Traffic Act and speeding.)

■ When performing the work, etc., be sure during the cold (when the engine and the muffler is cold). (It may cause burns.)

■ When performing the work, it should be made to prepare the tools for the job. (Breakage of parts, it may cause injury.)

■ Do the work must always specified torque using a torque wrench. (Damage of bolts and nuts, and cause of dropout.)

■ The product and the frame, might have edges or protrusions. Please go to protect your hands when you work. (It may cause injury.)

■ Be sure to each part inspection before operation, check the loosening of the threaded portion, be sure to securely tighten the specified torque if there is loose. (It may cause detachment of the parts.)

**! Warning** When the handling of ignoring this display people died, shows the contents of the serious injury possibility is assumed.

■ The technology and those who no knowledge, please do not to work. (The cause of parts damage etc., could result in falls and accidents.)

■ If you start the engine, be sure in a well-ventilated place. In the sealed such place, please do not start the engine. (There is a risk of carbon monoxide poisoning.)

■ During operation, when an abnormality occurs, immediately stop the vehicle in a safe place, please stop running. (It may lead to an accident.)

■ When performing the work, do the work safely stabilize the vehicle in a horizontal location. (There is a risk of injury vehicle collapsed while working.)

■ Inspection, maintenance, the instruction manual or, inspection methods such as service manuals, to protect the way, should be done correctly. (unsuitable inspection and maintenance, there is a risk that result to an accident.)

■ When carrying out the inspection and maintenance, etc., if found damaged parts, replace the damaged parts to avoid possible to reuse the parts. (There is a risk that lead to accidents Continued use.)

■ The engine and exhaust system are hot while the engine is running or for a while even the engine is stopped. Never place dangerous or flammable materials such as gasoline near working area. (May caused fire.)

◎ Please note. Performance up, the design change, the product and the price in the cost up, etc. are subject to change without notice.

◎ Please be informed that we shall be held harmless against any claim against us whatsoever arising out of use of the products in racing and the like.

◎ Keep this manual stored until this product is discarded.

**SPECIAL PARTS**  
**TAKEGAWA**

CONTACT Address : 3-5-16 Nishikiorihigashi Tondabayashi Osaka JAPAN

TEL: +81-721-25-1357 FAX: +81-721-24-5059 e-mail: english@takegawa.co.jp URL http://www.takegawa.co.jp

Please contact with your name and country name provided. (Only English please)

Product content

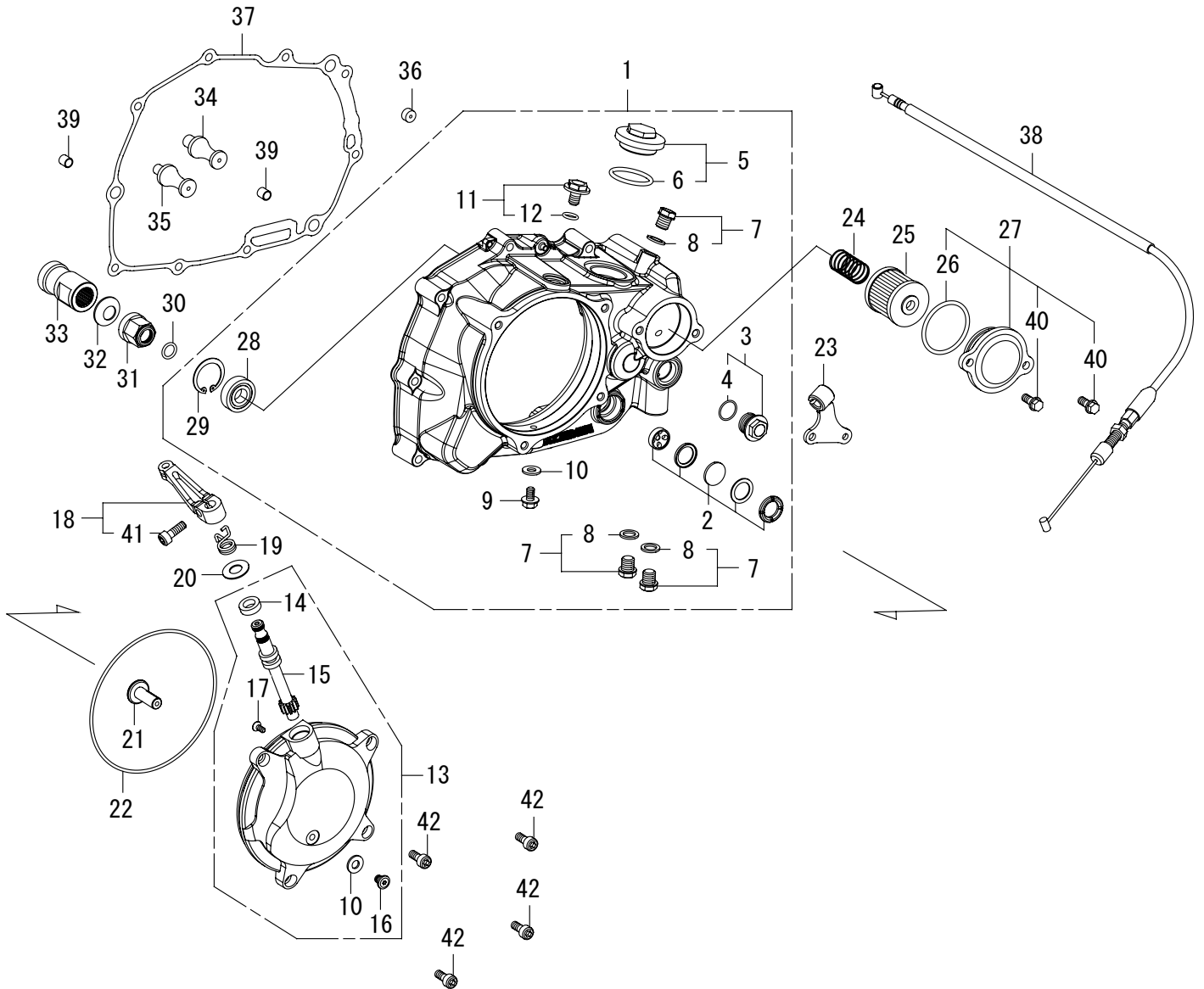

Number	Product content	Quantity	Item Number	Number	Product content	Quantity	Item Number
1	R.crankcase cover ASSY.	1	00-02-6208	22	O-ring, 120mm	1	00-02-0188
2	Oil pot window set	1	00-02-0031	23	Clutch cable receiver COMP.	1	00-00-1676
3	Thermostat hole cap	1	00-07-0063 (with O-ring)	24	Oil filter spring	1	00-07-0065
4	O-ring, 15mm	1	00-00-0185 (5 pcs)	25	Oil filter element	1	00-02-0027
5	Hole cap	1	09-06-0131 (with O-ring)	26	O-ring, 40mm	1	00-02-0040
6	O-ring, 30mm	1	00-01-0034 (4 pcs)	27	Oil filter cover	1	00-02-0470 (with O-ring/Bolt)
7	Oil plug bolt	3	00-07-0072 (with Sealing washer)	28	Boll bearing, 6001Z	1	00-01-1011
8	Sealing washer, 10mm	3	00-07-0106 (10 pcs)	29	C type ring, 28mm	1	00-00-0643 (3 pcs)
9	Flange bolt, 6x12	1	00-00-0322 (6 pcs)	30	O-ring, 12mm	1	00-00-0136
10	Sealing washer, 6mm	2	00-00-2780	31	Oil through nut	1	00-00-2310
11	Oil filler cap	1	00-02-0468 (with O-ring)	32	Conical spring washer, 14mm	1	00-02-0036
12	O-ring, 13mm	1	00-00-0644 (5 pcs)	33	Spacer	1	00-00-1414
13	Clutch cover COMP.	1	00-00-1089	34	Clutch lifter rod, 10mm	1	00-00-1684
14	Oil seal, 10x17x5	1	00-02-0006	35	Clutch lifter rod, 12mm	1	00-00-1685
15	Clutch release pinion	1	00-02-0033	36	Orifice	1	00-00-1072
16	Extra low head cap screw, 6x8	1	00-00-0642 (6 pcs)	37	R.crankcase cover gasket	1	00-02-0356
17	Flat head screw, 4x10	1	00-00-0190 (6 pcs)	38	Clutch cable COMP. 850mm	1	00-02-0133
18	Release arm	1	00-02-0469 (with Bolt)	39	Dowel pin, 8x12	2	00-00-0153 (2 pcs)
19	Clutch arm spring	1	00-02-0112	40	Flange bolt, 6x16	2	00-00-0879 (5 pcs)
20	Plain washer, 10mm	1	00-00-0151 (10 pcs)	41	Socket cap screw, 6x18	1	00-00-0720 (5 pcs)
21	Release rack	1	00-02-0039	42	Socket cap screw, 6x15	4	00-00-0718 (5 pcs)

※ Please order in the repair parts are always repair part number.

If it is not the part number order, you may not be able to order. Please be forewarned.

It should be noted, In the case of parts that can not be separately shipment, please order a set part number.

■ Mounting procedure ※ Please refer to the Genuine Service Manual for detailed mounting methods and specified torques that are not specifically described.

- Park the motorcycle in a horizontal place with a maintenance stand, etc.
- Drain engine oil.
- Remove the R. step holder.

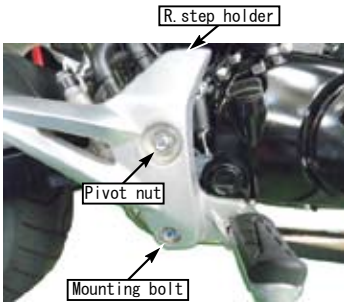

- Disconnect clutch cable.
- Loosen the bolts of the R. crankcase cover several times diagonally and remove the R. crankcase cover and clamp.



- Remove R. crankcase cover gasket, dowel pin and orifice.

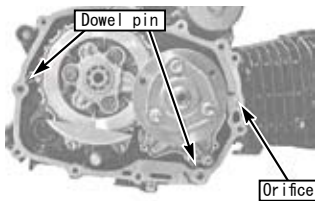

- Remove the bolt, centrifugal oil filter cover and gasket.

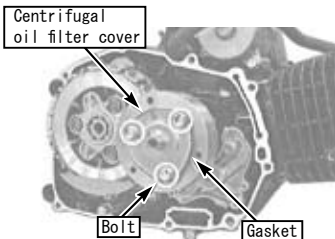

- Hold the primary drive gear and driven gear or the centrifugal oil filter rotor, and remove the centrifugal filter rotor lock nut using a special tool.

Special tool

: Genuine Honda tool

Lock nut wrench 07916-6390001

Gear holder 07724-0010100

: Takekawa tool

Lock nut wrench 00-01-0152

Universal holder 00-01-1002

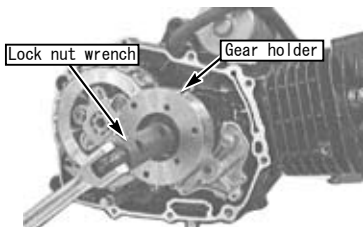

- Remove washers and centrifugal filter rotor.



- Attach the O-ring(12mm) to the oil through nut and apply a engine oil to the O-ring.

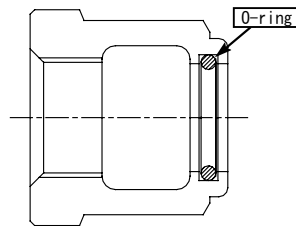

- Attach the spacer, conical spring washer, and oil through nut to the crankshaft in this order, hold the spacer with a spanner, and tighten the oil through nut to the specified torque.

▲ Note: Be sure that you protect specified torque.  
Nut  
Torque : 64N · m (6.6kgf · m)

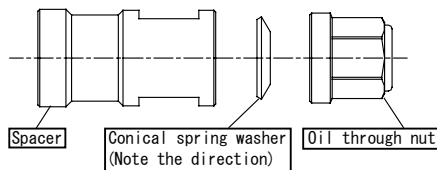

### Installing the clutch cover

- Clean the gasket surface of the R. crankcase, attach the dowel pin, and install a new R. crankcase cover gasket.
- Attach the orifice in the kit to the back of the R. crankcase.

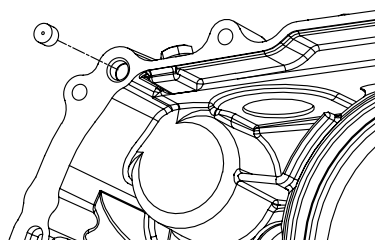

- Attach R. Crankcase cover, clamp and cable receiver COMP. with genuine bolts, divide bolts several times diagonally and tighten to specified torque.

▲ Note: Be sure that you protect specified torque.  
Bolt  
Torque : 10N · m (1.0kgf · m)

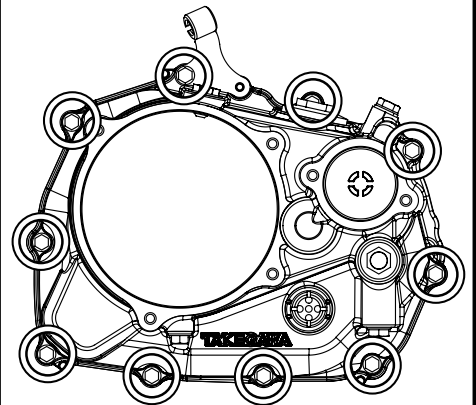
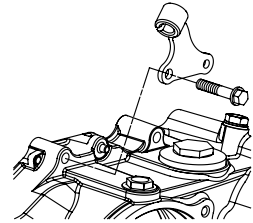

- Attach the lifter rod in the kit to the ball bearing on the clutch lifter plate.  
※ Use 10mm lifter rod for stock clutch, 12mm lifter rod for Takekawa slipper clutch.



- Attach the O-ring(120mm) to the clutch cover and apply a engine oil to the O-ring.



- Apply grease to the release rack and attach it to the clutch cover.



■ Mounting procedure ※ Please refer to the Genuine Service Manual for detailed mounting methods and specified torques that are not specifically described.

• Attach the clutch cover to the R. crankcase cover, install it with the socket cap screw (6x15) and tighten it to the specified torque.

▲ Note: Be sure that you protect specified torque.  
Socket cap screw, 6x15  
Torque : 10N · m (1.0kgf · m)

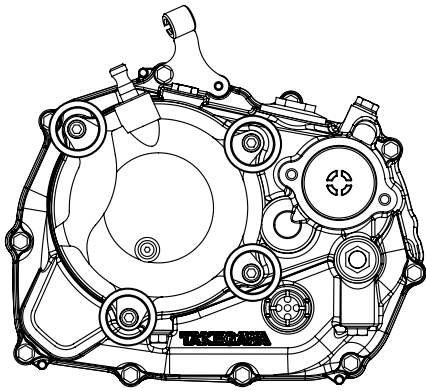

### Installing the oil filter cover

• Place the oil filter spring in the R. crankcase cover (fit it into the guide of the case), put the oil filter, attach the O-ring (40mm) to the oil filter cover, apply engine oil, and attach the flange bolt (6x16). Tighten with specified torque.

▲ Note: Be sure that you protect specified torque.  
Flange bolt  
Torque : 10N · m (1.0kgf · m)

※ Make sure the oil filter attached the guide on the oil filter cover.

※ Caution: If the oil filter spring does not fit inside of the guide (of the oil filter), there will be a gap between the oil filter cover and the R. crankcase cover. This may cause the oil leaks.

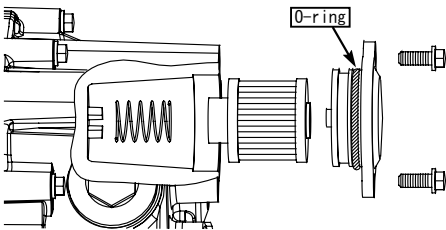

### Installing the clutch cable

• Attach the clutch cable to the clutch lever and route it to the clutch cable receiver for the cable is not overloaded.  
• Attach the adjuster of the clutch cable to the cable receiver.

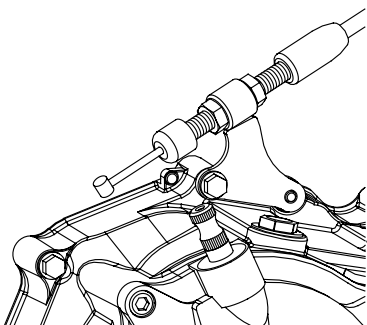

• Turn the clutch release pinion clockwise until it stops, and insert a plain washer into the release pinion.

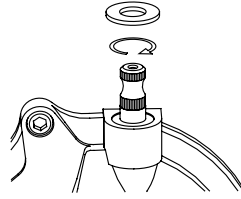

• Attach the cable end to the release arm, set the release arm spring, insert the inner cable into the release pinion while the cable pulled, and hook the arm spring to the cover.

• Attach the socket cap screw (6x18) to the release arm and tighten the socket cap screw to the specified torque with the arm pushed in.

▲ Note: Be sure that you protect specified torque.  
Socket cap screw  
Torque : 10N · m (1.0kgf · m)

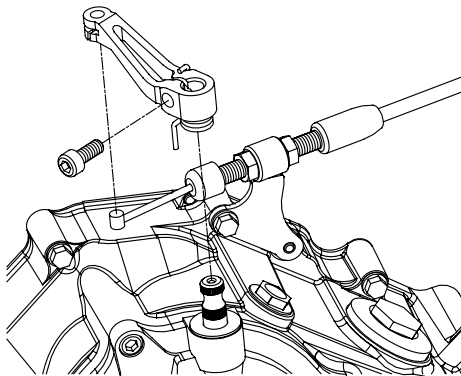

• Adjust the clutch free play at the adjustment part of the clutch cable, tighten the nut to the specified torque, and cover each with a rubber cap.

▲ Note: Be sure that you protect specified torque.  
Nut  
Torque : 10N · m (1.0kgf · m)

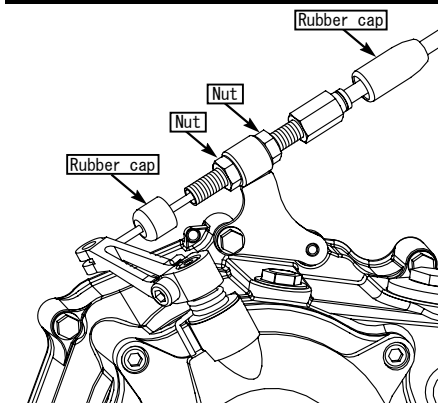

Clutch free play  
10 to 20 mm at the clutch lever end

10 ~ 20mm

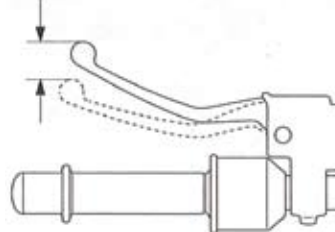

• For GROM (JC61-1300001 ~ /JC75-1000001 ~), MSX125SF

Since the rubber cap of the clutch cable and the clamp welded to the frame are close to each other, if they interfere, bend the clamp and provide clearance.

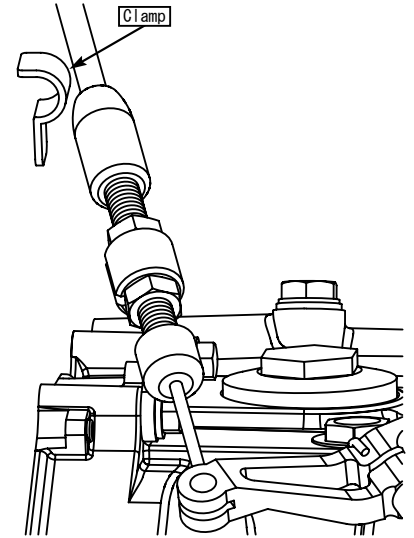

• Attach the removed R. step holder.

▲ Note: Be sure that you protect specified torque.  
Swing arm pivot nut  
Torque : 54N · m (5.5kgf · m)  
Step holder mounting bolt  
Torque : 31N · m (3.1kgf · m)

### After assembly

• After confirming that the drain bolt {T=21.5N · m (2.2kgf · m)} is tightened, pour engine oil, attach the O-ring to the hole cap, apply a small amount of engine oil to the O-ring. Tighten to the specified torque.

▲ Note: Be sure that you protect specified torque.  
Torque : 12N · m (1.2kgf · m)

※ Engine oil viscosity and volume affect clutch disengagement. Be careful to use high viscosity or volume of the oil.

Also, avoid excessive mixing of molybdenum, additives etc., as this may cause the clutch to slip.

※ Check the oil level of the oil window frequently, and add it if it is lower than the reference level.

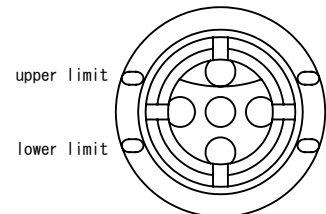

※ Oil volume when disassembling the crankcase : about 1100cc  
Oil volume for oil change : about 900cc

• Shift the transmission to first gear with the engine stopped and squeeze the clutch lever.

When moving the vehicle, make sure that the rear wheel does not rotate when the rear wheel rotates and the clutch lever is released.

• Start the engine with the transmission in neutral and check all parts for oil leaks. If there is no problems, test ride at low-speed in a safe place to check the operation of the clutch.

## Caution

### Precautions when installing an oil cooler

#### ● When installing an optional thermostat unit

- Installing the thermostat unit.
- Remove the two oil plug bolts, attach an adapter that matches the type of hose to be used, and connect the hose.
- ※ Check the thermostat unit instruction manual.
- ※ Check the oil cooler kit instruction manual and adapter instruction manual.

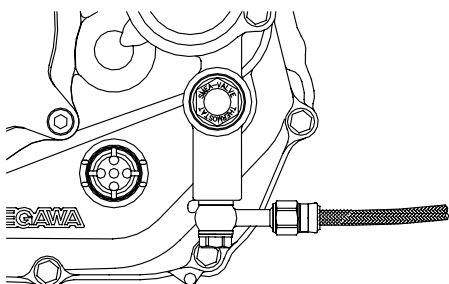

#### ● When not installing the thermostat unit

- Remove the thermostat hole cap and insert the oil hole plug (00-02-0391) into the oil hole.
- Apply engine oil to the O-ring of the thermostat hole and tighten the hole cap to the specified torque.

⚠ Note: Be sure that you protect specified torque.  
Hole cap  
Torque : 13N · m (1.3kgf · m)

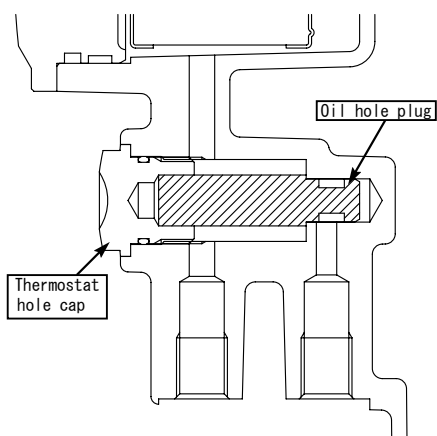

- Do not use oil hole plugs (00-02-0111).

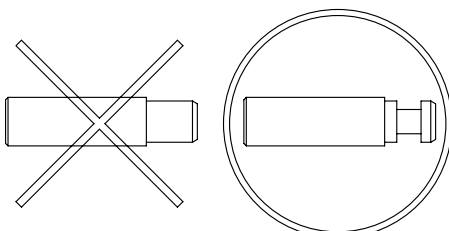

⚠ Note: If use the oil hole plug (00-02-0111), the oil passage will be closed and the engine may be damaged.

#### ● When installing an oil hose to the oil outlet of the cylinder

⚠ Note: Never attach the thermostat unit or oil hole plug when the oil hose is not connected to the clutch cover. Oil passage will be closed and engine may be damaged.

### When not installing an oil cooler

- Never install a thermostat unit or oil hole plug.  
Remove a thermostat unit or oil hole plug.

⚠ Note: When the thermostat unit or oil hole plug is installed, the oil passage is closed and the engine may be damaged.