



# Special Clutch Kit Instruction Manual

(Only for Aluminum Die Cast Clutch Cover Black paint/ Special Clutch 5 Disc Close ratio transmission, Only for Manual Clutch)

Item No. : 0 2 0 1 0 2 5 8

Fit: Frame No.:  
 Monkey Z50J-1300017 ~ /Z50J-2000001 ~ /AB27-1000001 ~ (6V centrifugal 3 speed vehicle excluded)  
 Monkey (FI) AB27-1900001 ~  
 Gorilla Z50J-1300027 ~ /Z50J-2500001 ~ /AB27-1000001 ~

- Thank you for purchasing one of our products. Please strictly follow the following instructions in installing and using the Kit.
- Before installing the Kit, please be sure to check the Kit contents. Should you have any questions about the Kit, please contact your local motorcycle dealer.

**Please note that, in some cases, the illustrations and photos may vary from the actual hardware.**

## Read all instructions first before starting the installation

We do not take any responsibility for any accident or damage whatsoever arising from the use of the product not in conformity with the instructions in this Instruction Manual.

We shall be held free from any kind of warranty whatsoever of products other than this product if the glitch takes place on the other products than this one after the installation and use of this product.

You are requested not to contact us about the combination of our product with other manufacturers'.

Please note that this Kit is designed for exclusive use in the above-mentioned compatible models and frame numbers only and that it cannot be mounted on any other models.

Those who are technically unskilled or inexperienced are required not to do the work. (Improper installation because of insufficient skill or knowledge could lead to parts breakage.)

Please note. Performance up, the design change, the product and the price in the cost up, etc. are subject to change without notice.

Please be informed that we shall be held harmless against any claim against us whatsoever arising out of use of the products in racing and the like. Keep this manual stored until this product is discarded.

This is a combined product of an Aluminum Die-Cast Cover Kit and a Special Clutch Kit (5 Disk) for use in a close ratio transmission motorcycle.

For installation, please refer to instruction manuals for relative products.

Genuine exhaust system and our up type exhaust system cannot be installed. When installing our Z style exhaust system, the cable receiver section of the clutch cover will interfere with the exhaust heat protector. It can be attached by processing the interference part of the exhaust heat protector.

When installing on a vehicle with frame number: 1300017 to 1510400, our clutch lever and combination switch, steering handle pipe are necessary separately.

(The contents of this kit is the kit contents for manual clutch vehicles.

For centrifugal 3-speed vehicles of frame number from 1300017 to 1510400, cannot be corresponded to by only parts included in this kit.)

For details, please visit our general catalog or WEB SITE.

## Important Notice

To install this kit, it is necessary to install 4, 5 or 6-speed close ratio transmission kit for our special clutch simultaneously.

### Kit includes:

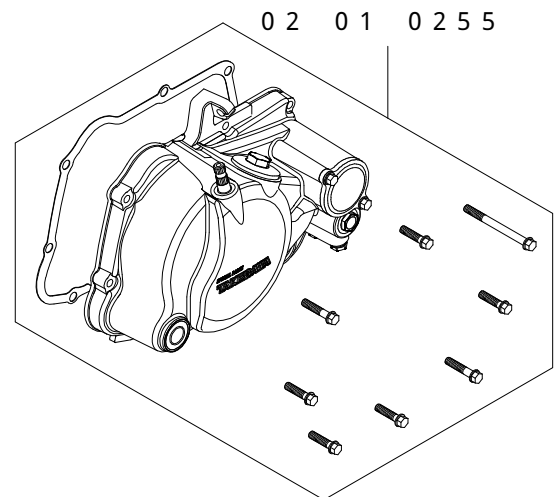
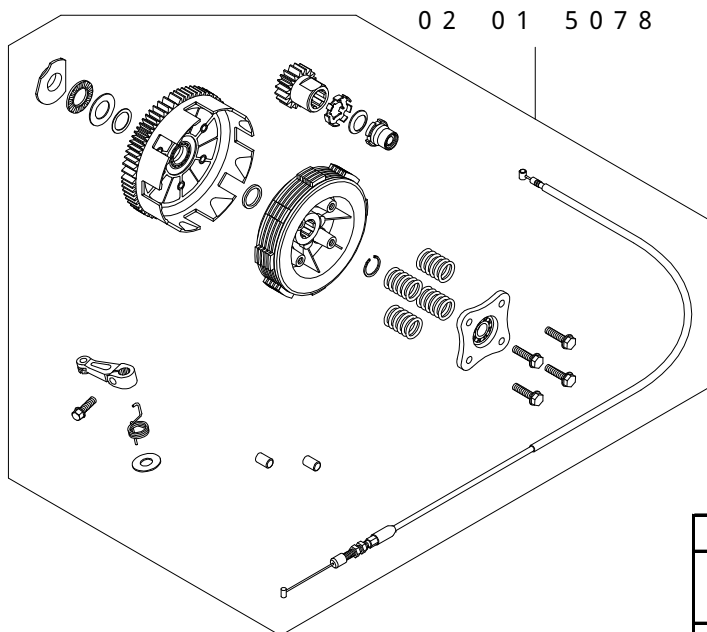

Item No.	Part Name	Qty
02-01-0255	Special Clutch Cover Kit (Aluminum Die-Cas / Black Painting)	1
02-01-5078	Special Clutch Kit (5 disk) (For close ratio transmission)	1

**SPECIAL PARTS TAKEGAWA** Co.,Ltd.

3-5-16 Nishikiorihigashi Tondabayashi Osaka Japan TEL:81-721-25-1357 FAX:81-721-24-5059 URL: <http://www.takegawa.co.jp>