



# Instruction Manual for Special Clutch Kit

(For use with magnesium die-cast cover.)

Item No. : 0 2 0 1 5 0 3 2

Fits: Frame Nos:  
DREAM50 AC15-1000001 ~

- Thank you for purchasing one of our TAKEGAWA-made products. Please strictly follow the following instructions in installing and using the Kit.
- Before installing the Kit, please be sure to check the Kit contents. Should you have any questions about the Kit, please contact your local motorcycle dealer.

## Read all instructions first before starting the installation

We do not take any responsibility for any accident or damage whatsoever arising from the use of the product not in conformity with the instructions in this Instruction Manual.

We shall be held free from any kind of warranty whatsoever of products other than this product if the glitch takes place on the other products than this one after the installation and use of this product.

If you make modifications to any product supplied here, we shall be held free from any guarantee of the product.

You are requested not to contact us about the combination of our product with other manufacturers'.

Please note that this Kit is designed for exclusive use in the above-mentioned compatible models and frame numbers only and that it cannot be mounted on any other models.

Those who are technically unskilled or inexperienced are required not to do the work. (Improper installation because of insufficient skill or knowledge could lead to parts breakage.)

Please be informed that, mainly because of improvement in performance, design changes, and cost increase, the product specifications and prices are subject to change without prior notice.

This product consists of the Magnesium Die-Cast Cover Kit and 5-Disk Heavy Duty Clutch Kit.

For installation, please refer to instruction manuals for relative products.

Please note that, in some cases, the illustrations and photos may vary from the actual hardware.

## Important Notice

With the installation of the 5-disk heavy duty clutch, the primary reduction gear ratio will be changed. Therefore, it is necessary to do the setting of the final gear.

## Kit includes:

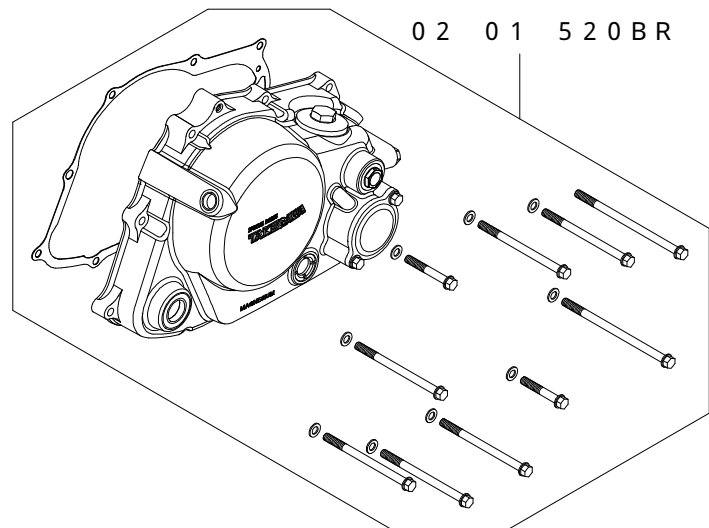
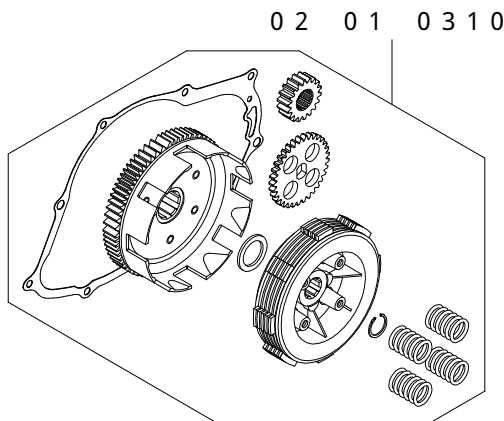

Item No.	Product name	Qty
02-01-520BR	Magnesium Die-Cast Clutch Cover Kit	1
02-01-0310	5-Disk Heavy Duty Clutch Kit	1

**SPECIAL PARTS TAKEGAWA** Co.,Ltd.

3-5-16 Nishikiorihigashi Tondabayashi Osaka Japan

TEL : 81-721-25-1357 FAX : 81-721-24-5059 URL : <http://www.takegawa.co.jp>