



# Special Clutch Kit Instruction Manual

( Aluminum die-cast clutch cover, black painted / for exclusive use with stock mainshaft.)

- Thank you for purchasing one of our products. Please strictly follow the following instructions in installing and using the Kit.
- Before installing the Kit, please be sure to check the Kit contents. Should you have any questions about the Kit, please contact your local motorcycle dealer.

**Please note that the descriptions in this manual like illustrations and photos may differ from the actual hardware.**

Item No. : 0 2 0 1 5 0 4 9

Fits: Frame No.:  
CRF50F AE03-1400001 ~  
XR50R AE03-1000001 ~

## Read all instructions first before starting the installation

We do not take any responsibility for any accident or damage whatsoever arising from the use of the product not in conformity with the instructions in this Instruction Manual.

We shall be held free from any kind of warranty whatsoever of products other than this product if the glitch takes place on the other products than this one after the installation and use of this product.

If you make modifications to any product supplied here, we shall be held free from any guarantee of the product.

You are requested not to contact us about the combination of our product with other manufacturers'.

Please note that this Kit is designed for exclusive use in the above-mentioned compatible models and frame numbers only and that it cannot be mounted on any other models.

Those who are technically unskilled or inexperienced are required not to do the work. (Improper installation because of insufficient skill or knowledge could lead to parts breakage.)

Please be informed that, mainly because of improvement in performance, design changes, and cost increase, the product specifications and prices are subject to change without prior notice.

This Kit comprises of a gearshift arm for a manual clutch and a clutch lever for a 22.2mm-diameter handle pipe in addition to Aluminum Die-Cast Cover Kit and Special Clutch Standard Kit for a stock mainshaft.

For installation, please refer to instruction manuals for relative products.

## Important Notice

- 1 .The supplied clutch lever is for installation only on a handle pipe of 22.2 mm in diameter. This clutch lever cannot be installed onto a stock handle pipe.
- 2 . A clutch cable adapter supplied in Special Clutch Standard Kit will not be used.

## Kit includes:

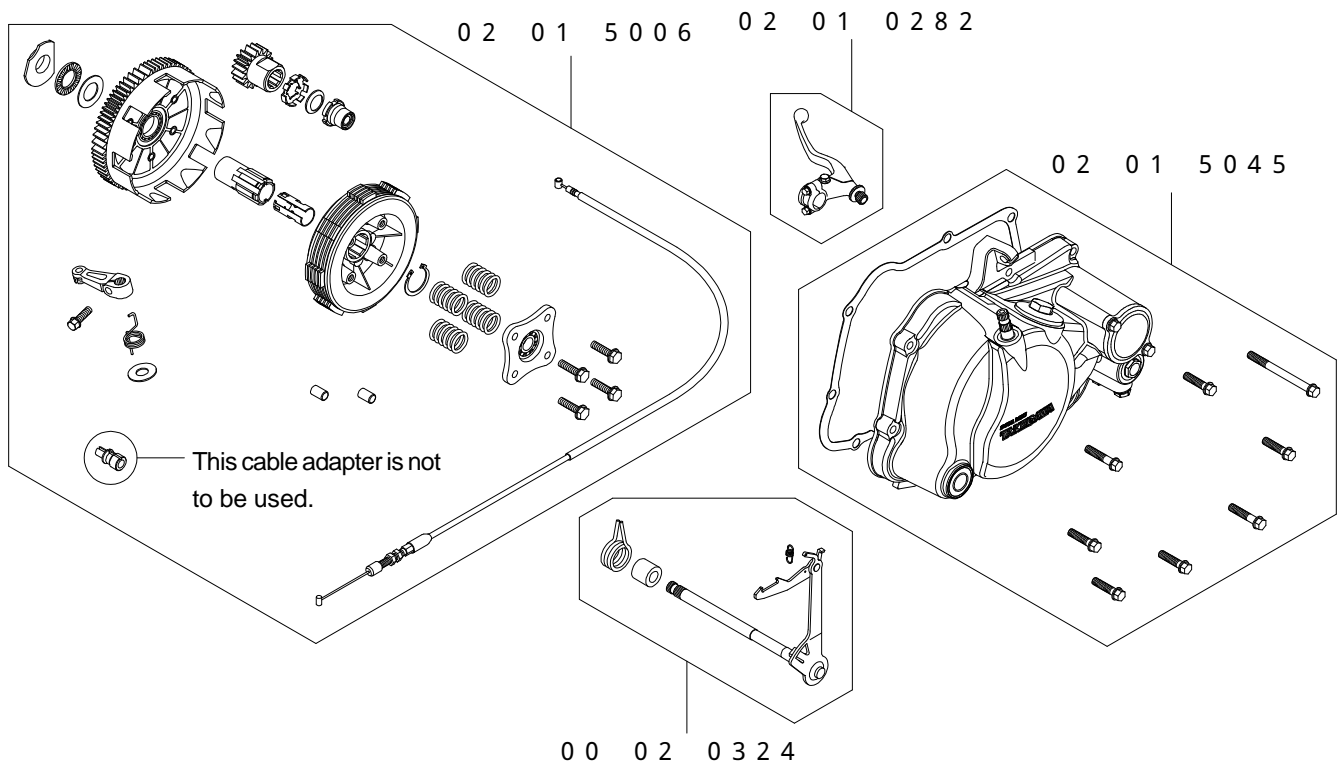

Item No.	Part Name	Qty
02-01-5045	Aluminum Die-Cast Clutch Cover Kit	1
02-01-5006	Special Clutch Standard Kit (for a stock mainshaft)	1
00-02-0324	Gearshift arm assembly (for manual clutch)	1
02-01-0282	Clutch lever assembly (silver)	1

**SPECIAL PARTS TAKEGAWA Co.,Ltd.**  
3-5-16 Nishikiorihigashi Tondabayashi Osaka Japan  
TEL : 81-721-25-1357 FAX : 81-721-24-5059  
URL : <http://www.takegawa.co.jp>

