



SPECIAL CLUTCH KIT Instruction Manual

(Slipper clutch / barrel)

- Thank you for purchasing one of our products.
Please strictly follow the following instructions in installing and using the Kit.
- Before installing the Kit, please be sure to check the Kit contents.
Should you have any questions about the Kit, please contact your local motorcycle dealer.

Item No. : 0 2 0 1 5 1 1 7

Applicable Model & Frame No.

DREAM 50 : AC15-1000001 ~

Please note: Illustrations and photos may vary from actual hardware.

Read all instructions first before starting the installation

We do not take any responsibility for any accident or damage whatsoever arising from the use of the product not in conformity with the instructions in this Instruction Manual.

We shall be held free from any responsibility or compensation whatsoever for any glitch in the parts other than ours if the glitch takes place after the installation and use of this product.

If you make modifications to any product supplied here, we shall be held free from any guarantee of the product.

You are requested not to contact us about the combination of our product with other manufacturers'.

Please note that this Kit is designed for exclusive use in the above-mentioned compatible models and frame numbers only and that it cannot be mounted on any other models.

Those who are technically unskilled or inexperienced are required not to do the work. (Improper installation because of insufficient skill or knowledge could lead to parts breakage.)

Please be informed that, mainly because of improvement in performance, design changes, and cost increase, the product specifications and prices are subject to change without prior notice.

This product consists of the Aluminium Clutch Cover Kit and Slipper Clutch Kit.

For installation, please refer to instruction manuals for relative products.

Important Notice

With the installation of the Slipper Clutch, the primary reduction gear ratio will be changed. Therefore, it is necessary to do the setting of the final gear.

Kit includes:

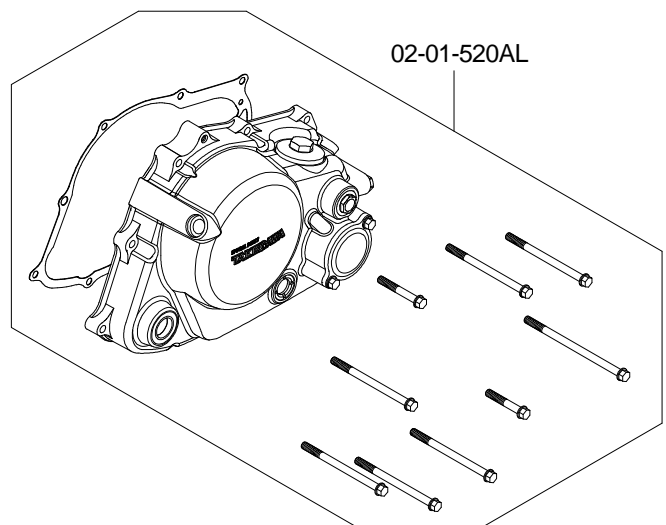
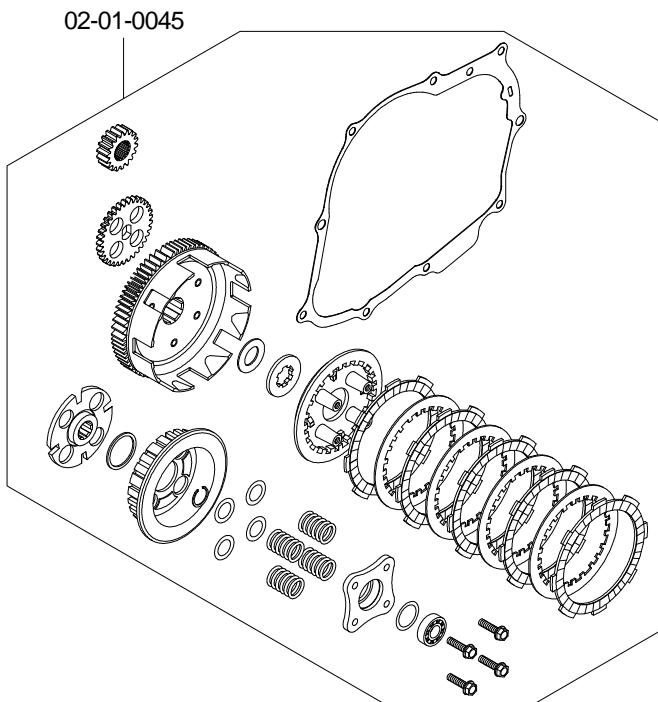

Item No.	Product name	Qty
02-01-520AL	Aluminium Clutch Cover Kit	1
02-01-0045	Slipper Clutch Kit	1

SPECIAL PARTS TAKEGAWA Co.,Ltd.

3-5-16 Nishikiorihigashi Tondabayashi Osaka Japan

TEL : 81-721-25-1357 FAX : 81-721-24-5059

URL : <http://www.takegawa.co.jp>