



KEIHIN PD22 Carburetor Kit Instruction Manual

Item No. : 0 3 0 5 0 1 0 7 (Paper-type filter)
: 0 3 0 5 0 1 0 8 (Sponge-type filter)

Applicable model and frame No.:

CRF50F : AE03-1400001 ~

XR50R : AE03-1000001 ~

- We are flattered that you have purchased one of our products. Please strictly follow the following instructions in installing and using the products.
- Before fitting the products, please be sure to check the contents of the kit. Should you have any questions about the products, please kindly contact your dealer.

Please note that, in some cases, the illustrations and photos may vary from the actual hardware.

Please do read the following before installation.

We do not take any responsibility for any accident or damage whatsoever arising from the use of the products not in conformity with the instructions in the manual.

We shall be held free from any kind of warranty whatsoever of products other than this product if the glitch takes place on the other products than this one after the installation and use of this product.

The installation of the products entails machining of a stopper on the throttle pipe. And please note that with the machining, an accelerator limiter will get unavailable.

Do the installation work correctly referring to Honda's genuine service manual for the above-mentioned applicable models.

This kit is designed for exclusive use in the above-mentioned applicable models and frame numbers only. Please take note that this kit cannot be mounted on other types of motorcycles.

If you make modifications to the products, we shall be held free from any guarantee of the products.

You are kindly requested not to contact us about the combination of our products with other manufacturers'.

Setting of a carburetor needs to be adjusted depending on the natural phenomena like the weather, temperatures, and motorcycles and carburetors themselves. Arrange the setting to match the engine and other conditions. For your information, the carburetor is shipped out in a state described on page 2.

Caution The following show the envisioned possibility of injuries to human bodies or property damages as a result of disregarding the following cautions.

- Work only when the engine and the muffler are cool. (Otherwise, you will burn yourself.)
- Prepare right tools for the work, (Otherwise, the installation with improper tools could cause breakage of parts or injuries to yourself.)
- Always use a torque wrench to screw bolts and nuts tight and securely to the specified torque.
(Improper torque could cause these parts to get damaged or fall off, resulting in accidents.)
- As some products and frames have sharp edges or protruding portions, please work with your hands protected.
(Otherwise, you will suffer injuries.)
- Before riding, always check every section for slack in parts like screws. If you find slack ones, screw them securely up to the specified torque. (Or improper torque may cause parts to come off.)
- Always use new gaskets and packings. And check those parts to be reused for wear and damage. If you find wear or damage, replace them with new ones.

Warning The following show the envisioned possibility of human death or serious injuries to human bodies as a result of disregarding the following cautions.

- Always start the engine in a well-ventilated place, and do not turn the engine on in an airtight place.
(Otherwise, you will suffer from carbon monoxide poisoning.)
- When you notice something abnormal with your motorcycle while riding down a road, stop riding immediately and park your motorcycle in a safe place. (Otherwise, the abnormality could lead to accidents.)
- Before doing work, secure the motorcycle on level ground for safety's sake.
(Otherwise, your motorcycle could overturn and injure you while you are working.)
- Check or carry out maintenance of parts correctly according to the procedures in the instruction manual or a service manual.
(Improper checking or maintenance could lead to accidents.)
- If you find damaged parts when checking and performing maintenance, do not use these parts any longer, and replace them with new ones.
(The continued use of these damaged parts could lead to accidents.)
- As gasoline is highly flammable, never place it close to fire. Make sure that nothing flammable is near the gasoline. Since vaporized accumulation of gasoline is at high risk of explosion, work in a well-ventilated place. (It may cause a fire.)

Please be informed that, mainly because of improvement in performance, design changes, and cost increase, the product specifications and prices are subject to change without prior notice.

This manual should be retained for future reference.

~ Kit Contents ~



Factory preset mode of the carburetor

Main jet	#95
Slow jet	#38
Jet needle	E2051G
Clip position	4th from the top
Throttle valve	74B
Air screw opening	1-1/4

No.	Part Name	Qty	Repair Part Item No.	in packs of
1	Carburetor assembly	1	03-05-0098	1
2	Inlet pipe	1	17113-GEF-T01	1
3	Inlet pipe gaslet	1	00-03-0009	3
4	Carburetor gasket	1	16210-GEF-T01	1
5	Socket cap screw, 6x70	1	00-00-0081	2
6	Socket cap screw, 6x25	2	00-00-0089	10
7	Socket cap screw, 6x20	1	00-00-0043	10
8	Lock nut 6mm	2	00-00-0533	10
9	Throttle cable, 710mm	1	09-02-0071	1
10	Fuel tank front spacer, 30mm	1	16951-GEL-T00	1
11	Fuel tank rear spacer, 20mm	1	16952-GEL-T00	1
12	Flange bolt, 8x55	1	00-00-0198	4
13	Flange bolt, 8x40	1	00-00-0197	4
14	Collar	1	00-00-0199	4
15	Washer	1	00-00-0201	6
16	Air filter	1	03-01-1134 (Paper-type)	1
			03-01-1136 (Sponge-type)	1
17	Main jet #105	1	00-03-0021	1
18	Slow jet #42	1	00-03-0140	1
19	Fuel hose, 200mm	1	00-03-0203	1
Tool	Hex wrench, 5mm	1		

Please order repair parts with the Repair Part Item No. Without the repair part item No., we may not be able to provide the correct parts.
Some parts are only available as a set. Please order them with the set number.

~ Installation Procedures ~

Make sure your bike is secure on level ground for safety's sake.

Shut off a fuel cock, and open a drain cock on the carburetor to drain gasoline from the float chamber.

1 . Detachment of Exterior Parts

First detach two trim clips, two screws and two bolts, and then detach an assembly of a seat, shroud and rear fender.

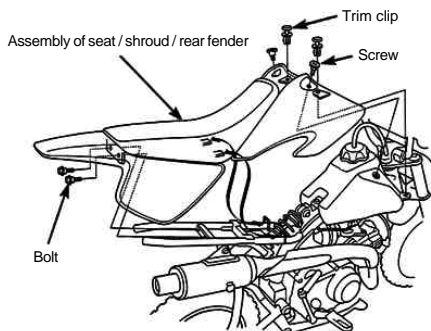

Detach a fuel hose from the carburetor, and detach two bolts to demount a fuel tank.

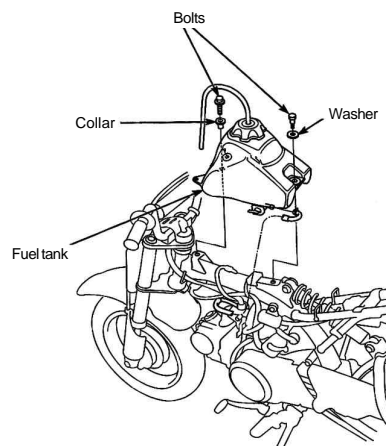

2 . Carburetor Detachment

First detach from the carburetor a top cap, hose of a storage tank, bolt on the air cleaner stay and two bolts on the manifold, and then detach a manifold, carburetor and air cleaner.

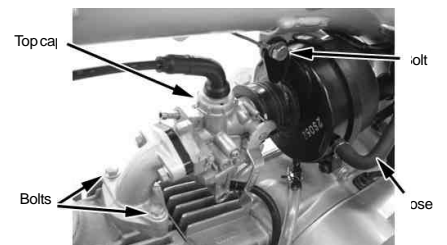

Attach an earth cable to the frame with the bolt on the air cleaner stay.

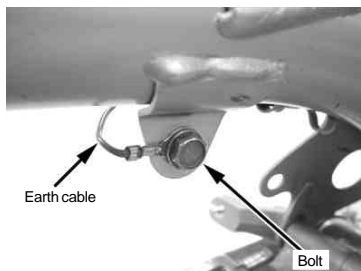

Detach a bolt, and pull out a breather hose from the crankcase to detach the storage tank.

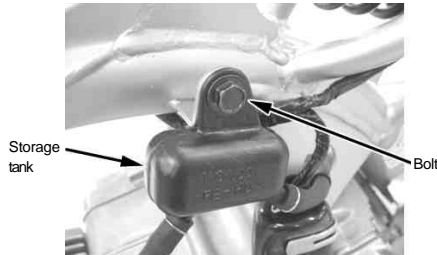

3 .Detachment of Throttle Cable

Loosen a hex nut on the throttle cable. Unfasten two screws, and detach a throttle housing and throttle pipe from the handle.



Detach a stock throttle cable from the lower throttle housing.

4 .Attachment of Throttle Cable

Machine the stopper on the throttle pipe to remove it.

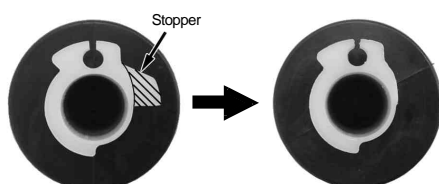

Attach a throttle cable of the kit to the lower throttle housing. Connect an inner cable to the machined throttle pipe, and fix the throttle housing to the handle with two screws.

Tighten hex nuts on the throttle cable.

5 .Attachment of Carburetor

Place a gasket between cylinder head and inlet pipe, and tighten the gasket with socket cap screws. And place a gasket between carburetor and inlet pipe, and tighten the gasket with socket cap screws and lock nuts.

⚠ Caution: Apply the specified torque.
Torque:10 N · m (1.0 kgf · m)

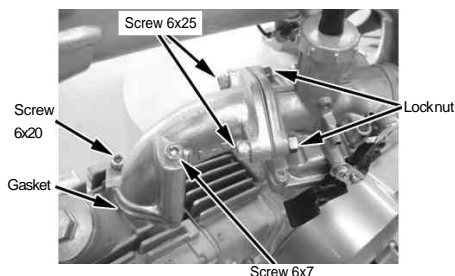

Take a top cap off the carburetor to pull out a spring and throttle valve. Attach the carburetor top cap, spring and throttle cable to the throttle cable.



Attach the throttle valve to the carburetor, aligning the notch with the throttle stop screw. Snap the throttle a few times to check how much the throttle valve opens and closes.

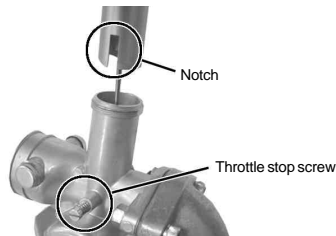

Adjust the free play at the throttle grip to be about 5 mm with an adjuster on the throttle cable. Attach and fix an airfilter by fastening a band. You are requested to dispose of the blow-by gas from the crankcase by yourself. (For example: Attach the storage tank so the air filter does not interfere with the tank, and let the blow-by gas into the air filter with a breather hose of the kit.)



6 . Attachment of Exterior Parts

Put a front tank spacer between the front fuel tank and frame, and attach a bolt. And put a rear tank spacer between the rear fuel tank and frame, and attach the collar and kit's washer, and fasten the bolt.

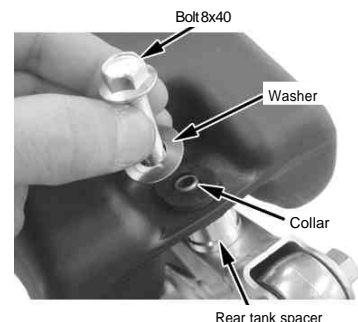
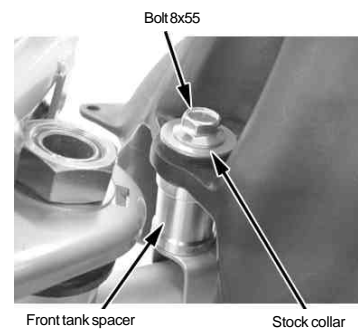

Put a prong on the back of the seat into a hook on the frame, and attach an assembly of seat / shroud / rear fender with two each of trim clips, screws and bolts.

Pulling the shroud, align the mounting hole with a threaded screw hole in the fuel tank, and fit two screws into the holes.

In case it's hard to fit the screws, elongate the holes with a rasp and the like.



SPECIAL PARTS TAKEGAWA Co.,Ltd.

3-5-16 Nishikiorihigashi Tondabayashi
Osaka Japan

TEL : 81-721-25-1357 FAX : 81-721-24-5059
URL : <http://www.takegawa.co.jp>

How to Set the Carburetor

- When the carburetor does not match the engine and the engine fails, the engine failures are caused by either too dense or too lean air-fuel mixture.
- The engine failure symptoms for the engine are as follows:

When the air-fuel mixture is too dense:	When the air-fuel mixture is too lean:
<ul style="list-style-type: none"> • The explosion sound with a dull thud continues intermittently. • The engine malfunctions further if you use the choke. • The engine malfunctions when you warm it up. • The engine works well if the cleaner is detached. • The motorcycle belches dense (or, black) exhaust gas. • The plug smolders, getting blackened. 	<ul style="list-style-type: none"> • The engine overheats somewhat. • The engine starts working well if you use the choke. • The engine does not accelerate well. (No smooth acceleration) • Revolutions change, generating weak power. • The plug burns white.

Set the carburetor only after warming up the engine, and then test-drive. And use a plug with the right heat value. Do the setting in the following manner, studying at what throttle opening position the engine starts failing.

Jet needle (Throttle position at 1/4 - 3/4)

Whether or not the engine revolution is in proportion to the throttle operation

- When the acceleration is not smooth or even, make the air-fuel mixture dense.
- Make the air-fuel mixture lean when the engine revolution goes up heavily and belches black gas.

The mixture ratio at this throttle position can be adjusted by the location of E-ring in the grooves. The air-fuel mixture becomes dense as the location of the E-ring moves down from the 1st to the 5th groove.

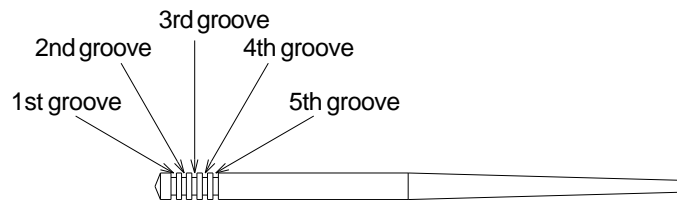

Main jet (The throttle position at 3/4 - 4/4)

The air-fuel mixture ratio at this throttle position can be adjusted by changing the number of the main jet. The larger the main jet numbers, the denser the mixture ratio becomes.

In view of the engine and muffler specifications, select the most appropriate main jet to get the highest revolutions.

Pilot jet (First of all, please adjust the air screw.)

- In case you have given more than three turns to the air screw to tighten it, use a pilot jet with a small number.
 - If you have tighten the air screw (clockwise) to the full, use a pilot jet with a larger number.
- Check whether you have made a right choice of the pilot jet by seeing if the engine starts up revolving smoothly from the idling to running at slow speed.
- When the engine revolves up unevenly, the pilot jet number is too small. (At idle)
 - When the motorcycle belches black exhaust gas and produces heavy exhaust sound, the pilot jet number is too big. (At idle)
 - After replacing the pilot jet, you need to readjust the airscrew.

Air screw

The air screw adjusts the air mass flow at the time of engine's revolving at slow speed. (At idling)

- Give the air screw a right turn The air-fuel mixture gets dense.
- Give the air screw a left turn The air-fuel mixture gets lean.

Loosen the tightened air screw back to the 1.5-turn position. And then from this position, give to the airscrew a right or left turn of 1/4 to 1/2 till the engine revolves at the highest speed.

Loosen the idle stop screw till you get the steady idling revolutions. And once again adjust the position of the airscrew to get the highest revolutions.

On how the barometric pressure, temperatures and humidity affect the setting:

- At highlands or at high altitudes, the barometric pressure and air density go down and the air gets into the carburetor in less amounts. This makes the air-fuel mixture dense which was adjusted at low altitudes.
- Under the weather conditions with very low temperatures, the air density increases, which makes the air-fuel mixture lean.
- Under the rainy and humid weather conditions, the air density decreases, which makes the air-fuel mixture dense.

Please be informed that, mainly because of improvement in performance, design changes, and cost increase, the product specifications and prices are subject to change without prior notice.

This manual should be retained for future reference.

SPECIAL PARTS TAKEGAWA Co.,Ltd.

3-5-16 Nishikiorihigashi Tondabayashi Osaka Japan TEL: 81-721-25-1357 FAX: 81-721-24-5059 URL: <http://www.takegawa.co.jp>