



Z-Style Muffler Instruction Manual

Item No. : 0 4 - 0 2 - 2 3 0 1

Applicable to : Monkey · Gorilla

Frame No. : Z50J -1300017 ~

: AB27-1000001 ~

Thank you for purchasing one of our TAKEGAWA's products. Please strictly follow the following instructions in installing and using the products. Before fitting the products, please be sure to check the contents of the kit. Should you have any questions about the products, please kindly contact your dealer.

Before installation, please read this instruction manual carefully and understand the instructions fully.

Enjoy the sound and performance of this muffler distinct from a stock muffler.

Please note that the descriptions in this manual like illustrations and photos may differ from the actual hardware.

~ Features ~

This is a genuine-like up-muffler for the Monkey, to which a genuine muffler guard can be installed.

It improves the performance without altering the original look of the Monkey.

We have adopted a silencer body and exhaust pipe, both made of stainless, to improve the appearance and durability.

Please read the following instructions before installation.

The following show the envisioned possibility of injuries and damages to human bodies, and physical loss or damage as a result of disregarding the following cautions.

We shall be held free from any kind of warranty whatsoever of products other than this product if the glitch takes place on the other products than this one after the installation and use of this product.

This product is designed for exclusive use in the above-mentioned types of motorcycles and frame numbers only. Please take note that this product cannot be mounted on other types of motorcycles.

Please refrain from combined use of this kit with with any other part than the specified parts.

Though a genuine muffler guard can be fixed as it is, processing is necessary as the guard-mounting portion is partially exposed.

This product is designed for exclusive use in a stock kick starter arm. (In case of TAKEGAWA's kick starter, the arm will interfere with the genuine muffler guard.)

This product cannot be used together with a (wire-type) Dry-Type Clutch Kit of 02-02-0143. For the installation of the said Kit, the installation of a Hydraulic Clutch Kit of 02-02-0144 is necessary.



CAUTION

The following show the envisioned possibility of injuries and damages to human bodies, and property loss as a result of disregarding the following cautions.

- Always try to drive your motorcycle at a legal speed, abiding by the laws.
- Work only when the engine and the muffler are cool. (Otherwise, you will burn yourself.)
- Prepare right tools for the work, and do the work in the proper and right way.
(Otherwise, improper work could cause breakage of parts or injuries to yourself.)
- Always use a torque wrench to screw bolts and nuts tight and securely to the specified torque.
(Improper torque could cause these parts to get damaged or fall off.)
- As some products and frames have sharp-pointed or protruding portions, please work with your hands protected.
(Otherwise, you will suffer injuries.)
- Do water washing of a muffler only when it is cool. (Otherwise, the muffler may be cracked.)
- Park your motorcycle in a place where pedestrians will not touch the muffler accidentally. Besides, please always be considerate enough not to park it in the way of pedestrians or moving vehicles.
(If you park your motorcycle on the sidewalk with its muffler on the pedestrians' side, the pedestrians may touch the muffler and get burned or suffer property loss.)
- Before riding, always check every section for slack in parts like screws. If you find slack ones, screw them securely up to the specified torque. (Or improper torque may cause parts to come off.)
- This muffler is designed for exclusive use in a stock kick starter arm. TAKEGAWA's kick starter arm will interfere with the genuine muffler guard.

**WARNING**

The following show the envisioned possibility of human death or serious injuries to human bodies as a result of disregarding the following cautions.

- Always drive the engine in a well-ventilated place, and do not switch the engine on in an airtight place.
(Otherwise, you will suffer from carbon monoxide poisoning.)
- Never look into the muffler outlet when the engine is revolving. (Otherwise, you will suffer from carbon monoxide poisoning or lose your sight.)
- When you notice something abnormal with your motorcycle while riding down a road, stop riding immediately and park your motorcycle in a safe place. (Otherwise, the abnormality could lead to an accident.)
- Before riding, be sure to always check the bank angle, and run with care not to bank the vehicle more steeply than the bank angle.
(Otherwise, there will be a danger of the motorcycle overturning.)
- The engine and the muffler are at high temperatures when the engine is revolving or for some time after the engine stopped. Therefore, never place flammable or hazardous materials such as gasoline near them. (Otherwise, there will be a danger of causing fires.)
- Before doing work, place the motorcycle on level ground to stabilize the position of your motorcycle for safety's sake.
(Otherwise, your motorcycle could overturn and injure you while you are working.)
- Check or perform maintenance of parts correctly according to the procedures in the instruction manual or a service manual.
(Improper checking or maintenance could lead to an accident.)
- If you find damaged parts when checking and performing maintenance, do not use these parts any longer, and replace them with new ones.
The continued use of these damaged parts as they are could lead to an accident.)
- Keep plastic bags for packing products out of children's reach, or discard them.
(If children get them on, there will be a danger of their suffocating.)
- Basically, you can install this muffler in almost the same way as installing a stock muffler. Although a genuine muffler can be fixed, a guard for an exhaust pipe (right behind the engine exhaust) cannot be installed. So, please do be careful not to let your right leg touch the exhaust pipe when pressing down on the rear brake pedal.
Besides, do not ride the vehicle in an exposed style, such as in sandals. (It could lead to burn or accidents.)

Please be informed that, mainly because of improvement in performance, design changes, and cost increase, the product specifications and prices are subject to change without prior notice.

A defective product which we acknowledge is caused by product materials or defect in manufacturing will be repaired or replaced with a new one by us at our expense, if and when a claim is filed with us within one (1) month of your purchase. However, replacing of parts shall be made at users' expenses. And we shall be held free from responsibility for any defect caused by improper installation or use.

Please be informed that we shall be held harmless against any claim against us whatsoever arising out of use of the products in racing and the like.

You are kindly requested not to contact us about the combination of our products with other manufacturers'.

You are requested to keep this instruction manual until you discard this product.

~ Kit Contents ~

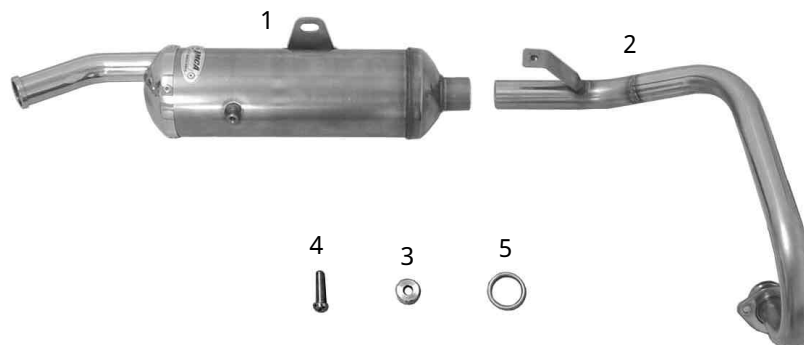

No.	Parts Name	Qty
1	Silencer assembly	1
2	Exhaust pipe	1
3	Collar	1
4	8x30 mm button head socket screw	1
5	Exhaust gasket	1

~ Installation Procedures ~

Stabilize the vehicle with a maintenance stand or the like in a safe and level place during work.

Genuine Muffler Removal

- 1 . Unscrew the bolts on the air cleaner stay.

⚠ CAUTION : Work only when the engine and the muffler are cool.

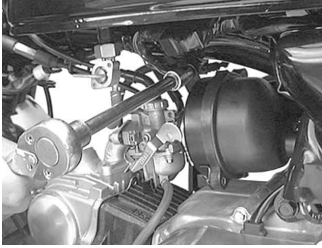

- 2 . Loosen the band which is clamping the carburetor and the air cleaner, and remove the air cleaner.



- 3 . Unfasten the nut on the back side of the muffler.

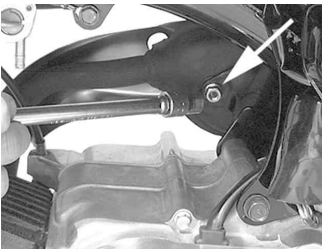

- 4 . Unfasten two nuts on the exhaust pipe flange. Keep them for re-use. If the nuts are worn or damaged severely, replace them with new ones.



- 5 . Unfasten the hex' bolt which is fixing the muffler.



- 6 . After removing two collars on the exhaust flange, remove the muffler from the body by pulling it outward.

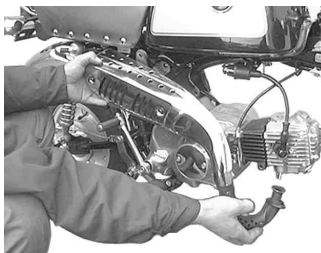
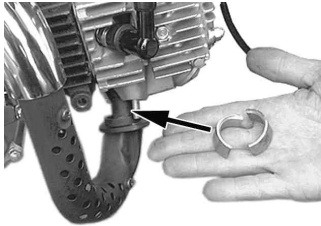
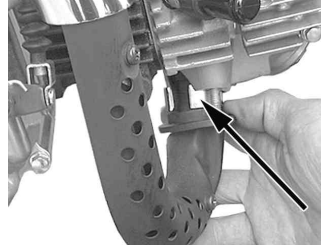

- 7 . Remove the old exhaust pipe gasket remaining in the exhaust port.

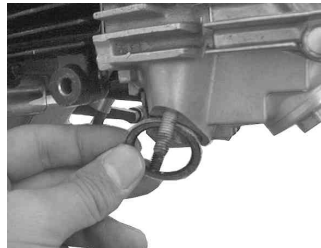

- 8 . Reinstall the removed air cleaner in the order opposite to its removal. On to a 12V motorcycle, never forget installing earth wires.

Torque : 8 ~ 10 N · m (0.8 ~ 1.0 kgf · m)

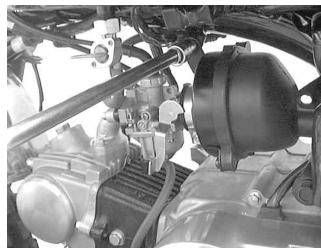

Genuine Muffler Guard Removal

- 1 . Detach the muffler guard from the just-removed genuine muffler.
- 2 . Unscrew all plus screws which are fixing the muffler guard to the muffler. Keep those screws for re-use. If the screws are worn or damaged severely, replace them with new ones.

⚠ CAUTION: Plus screws may be very tightly screwed, so unscrew them with enough care not to damage their heads.

- 3 . Though the genuine muffler guard can be installed as it is, the stay, which is fixing the guard on the exhaust pipe, gets exposed without processing. Therefore, cut off the unnecessary part.

⚠ CAUTION: Once the stay is processed or cut off, the guard on the exhaust pipe of the normal muffler will be rendered not installable any more.



- 4 . If the exposing portion is cut off, it is advisable to give a touch-up to the cut surface with a heat-resistant paint to prevent the surface from rusting.

Z-Style Muffler Installation

- 1 . Insert and install a kit's exhaust pipe gasket to the exhaust port.

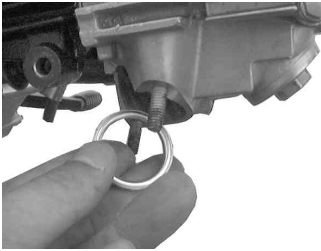

- 2 . Temporarily install the silencer assembly to the vehicle in the following order. First, pass the rear end of the silencer pipe from behind the upper part of the right-side rear shock absorber. Then pass the button head socket cap screw through the silencer stay. Finally, pass the collar from behind and temporarily fix the silencer on the frame.

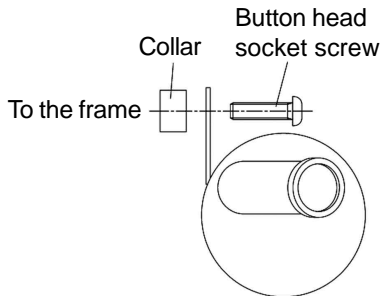

- 3 . After inserting the exhaust pipe into the joint on the silencer assembly, insert its flange into the engine.

It is advisable to apply heat-resistant liquid gasket to the inserting portion.
(ThreeBond 1207B or the equivalent.)

- 4 . Pass the exhaust pipe flange through the stud bolt of the cylinder head, and fix it temporarily with the nuts which were used to fix the genuine muffler.

- 5 . Check the clearance between the silencer's exhaust pipe and the rear fender, and then adjust the positions of the silencer and the exhaust pipe so that they do not interfere with each other.



- 6 . Tighten the exhaust pipe flange nuts evenly to the specified torque with care not to let the silencer and the exhaust pipe get out of the adjusted places.

Torque : 10 ~ 12 N · m (1.0 ~ 1.2 kgf · m)



- 7 . Next, tighten the button head socket screw on the silencer stay to the specified torque.

Torque : 27 N · m (2.7 kgf · m)

- 8 . Install the genuine muffler guard. Reuse the genuine plus screws.

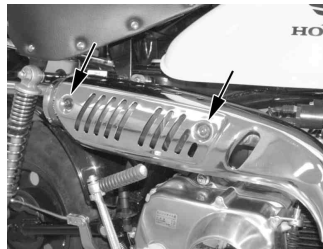

- 9 . Check for interference among the genuine muffler guard, the muffler, and the frame. If need be, loosen the screws and nuts on each section to adjust the positions to the extent that the adjusting does not place too much strain on the muffler. Then fix them.

Final Checking

- 1 . Start the engine in a safe and well-ventilated place, and check for exhaust leak or interference.
- 2 . After stopping the engine and after each part has cooled down to the normal temperatures, re-tighten all screws and nuts to the specified torque.

SPECIAL PARTS TAKEGAWA Co.,Ltd.

3-5-16 Nishikiorihigashi Tondabayashi
Osaka Japan

TEL : 81-721-25-1357 FAX : 81-721-24-5059

URL : <http://www.takegawa.co.jp>