



Instruction Manual for SILENT BOMBER AF

Item No. : 0 4 0 2 2 7 4 1

Fitting models and frame Nos:

AddressV125:CF4EA-100047 ~ (UZ125GK9 / ZK9)

△ CF46A-100000 ~ Note that this product cannot be installed onto the frame numbers of UZ125K5 / K7.

- Thank you for purchasing one of our TAKEGAWA's products. Please strictly follow the following instructions in installing and using the products.
- Before installing the products, please be sure to check the product contents. Should you have any questions about the products, please contact your local motorcycle dealer.
- This muffler with a built-in catalyzer conforms to the Japanese emission gas standards which came into effect in 2007 in Japan. So, you can be free from any anxiety in using this product for riding on the public road.
Enjoy the sound different from the one from the original muffler.

Please note that, in some cases, the illustrations and photos may vary from the actual hardware.

Read all instructions first before starting the installation

We do not take any responsibility for any accident or damage whatsoever arising from the use of the kit not in conformity with the instructions in the manual.

We shall be held free from any kind of warranty whatsoever of products other than this product if the glitch takes place on the other products than this one after the installation and use of this product.

You are kindly requested not to contact us about the combination of our products with other manufacturers'.

Please note that this product is designed for exclusive use in the above-mentioned fitting models and frame numbers only and that it cannot be mounted on any other models.

For the correct installation of this product, please refer to a Suzuki's genuine parts service manual for your vehicle.

Please do installation with right tools and with great care following the installation instructions. We advise those who are technically inexperienced or without right tools to ask a technically-trustworthy specialist shop to do the work.

Bolts and packing will be reused. However, be sure to replace worn-down or severely-damaged ones with new ones.

In the case of a stock bike, be sure to change weight rollers to the provided ones in order to ensure maximum performance of this product.

Do not remove the blind plug on the exhaust pipe except when you install an extra-cost AF meter (Item No.: 07-04-0032). Additionally, do not ride the bike with the blind plug detached, which causes engine troubles.

CAUTION

The following show the envisioned possibility of injuries to human bodies and property damage as a result of disregarding the following cautions.

- Always try to drive your motorcycle at a legal speed, abiding by the laws.
- Work only when the engine and muffler are cool. (Otherwise, you will get burned.)
- Do the installation with right tools. (Otherwise, breakage of parts or injuries to you may take place.)
- Always use a torque wrench to screw bolts and nuts tight and securely to the specified torque.
(Otherwise, these parts may get damaged or fall off, resulting in accidents.)
- As some products and frames have sharp edges or protruding portions, please work with your hands protected.
(Otherwise, you will suffer injuries.)
- Before riding, always check every hardware for slack in parts like screws. If you find slack ones, screw them securely up to the specified torque.
(Otherwise, improper tightening may cause parts to come off.)
- Check those parts, to be reused such as bolts and packing, for wear or damage. If you find worn or damaged parts, replace them with new ones.

WARNING

The following show the envisioned possibility of human death or serious injuries to human bodies as a result of disregarding the following warnings.

- Always start the engine in a well-ventilated place, and do not turn on the engine in an airtight place.
(Otherwise, you will suffer from carbon monoxide poisoning.)
- When you notice something abnormal with your motorcycle while riding, immediately stop riding and park your motorcycle in a safe place to check what has gone wrong. (Otherwise, the abnormality could lead to accidents.)
- Before doing work, make sure your motorcycle is secure on level ground for safety's sake.
(Otherwise, your motorcycle could overturn and injure you while you are working.)
- Check or carry out maintenance of your motorcycle correctly according to the procedures in the instruction manual or service manual.
(Improper checking or maintenance could lead to accidents.)
- If you find damaged parts when checking and performing maintenance of your motorcycle, do not use these parts any longer, and replace them with new ones. (The continued use of these damaged parts as they are could lead to accidents.)
- Keep plastic bags for packing the products out of infants' reach, or discard the bags. (If infants get a bag on, there is a risk of their suffocating.)

Please be informed that, mainly because of improvement in performance, design changes, and cost increase, the product specifications and prices are subject to change without prior notice.

This manual should be retained for future reference.

~ Kit Contents ~

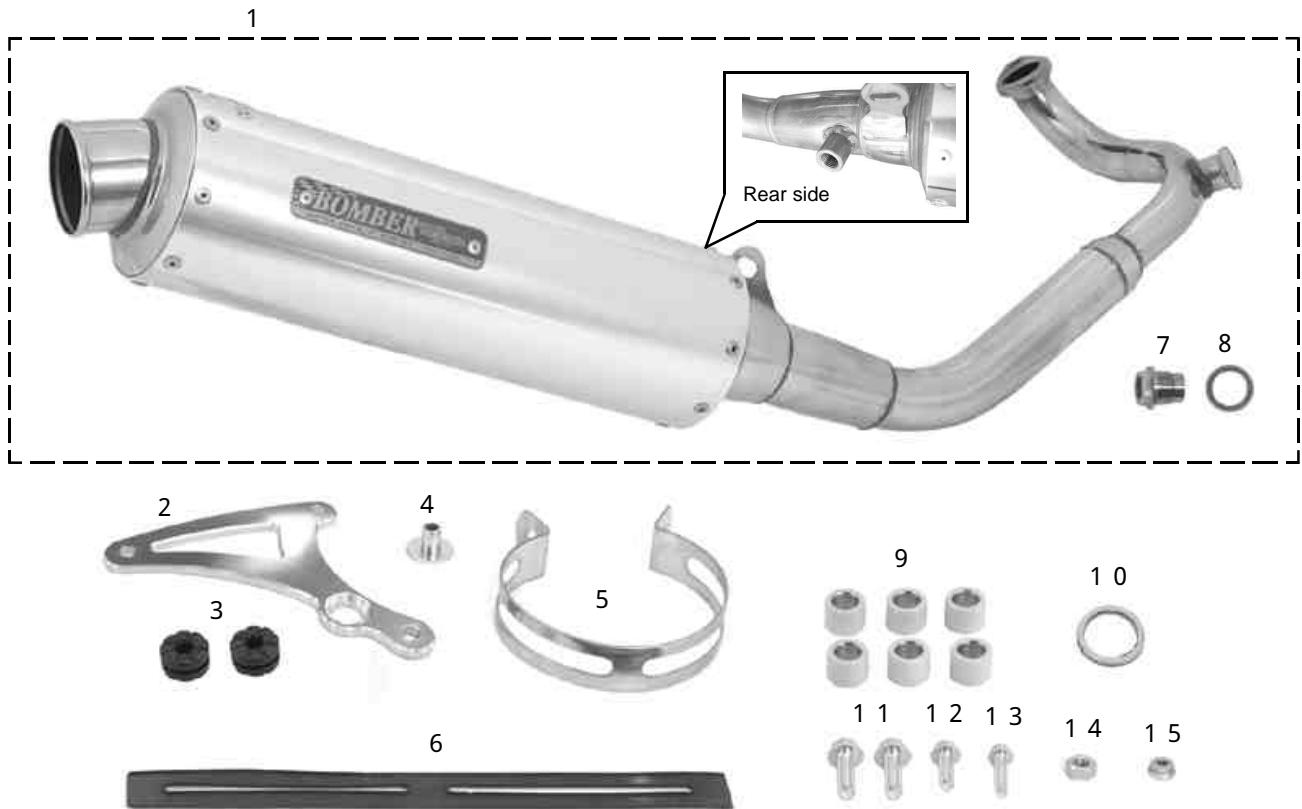

No.	Part Name	Qty	Repair Part Item No.	In units of
1	Muffler COMP.	1	_____	_____
2	Stay	1	91122-33G-T10	1
3	Rubber	2	00-00-0099	4
4	Collar	1	00-00-0217	4
5	Clamp band	1	00-04-0005	1
6	Band rubber	1		1
7	Blind plug	1	07-04-0023	1
8	Sealing washer, M18	1		1
9	Weight roller, 15 g	6	02-00-0004	3
10	Exhaust gasket	1	00-01-0063	2
11	Flange bolt, M10 x 25	2	00-00-0218	2
12	Flange bolt, M8 x 20	1	00-00-0211	4
13	Flange bolt, M6 x 25	1	00-00-0115	5
14	Flange nut, M8	1	00-00-0275	6
15	Flange nut, M6	1	00-00-0173	6

Please note that in ordering repair parts, be sure to quote the Repair Part Item No. Otherwise, we may not be able to accept your orders. There are some parts, however, for which we are not in a position to accept your order in just the quantity to be used. In this case, please take them in the quantity packed.

Rubber (No.3) comes with one piece of spare.

Compact LCD A/F meter (extra-cost products)

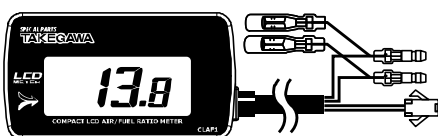

Features

With the help of a sensor installed in the exhaust pipe, the real-time air-fuel ratio is displayed in a digital format.

You can use this product supplementarily as a guideline for setting the air-fuel ratio.

As you can see the change in the air-fuel ratio in real time, this will help you notice the lean combustion at an early stage.

0 7 0 4 0 0 3 2

~ Installation Instructions ~

~ Change of Muffler ~

Removal of O₂-type sensor:

- 1 . Remove a filler cap and a screw, and pull a trunk box upward to remove it.

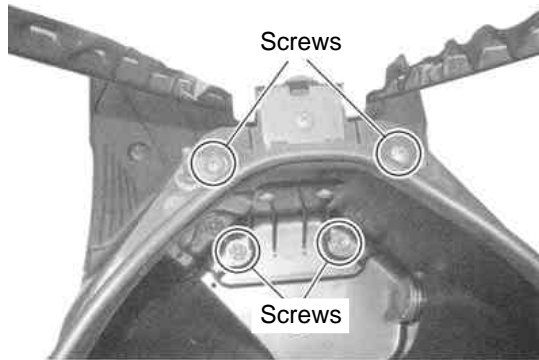
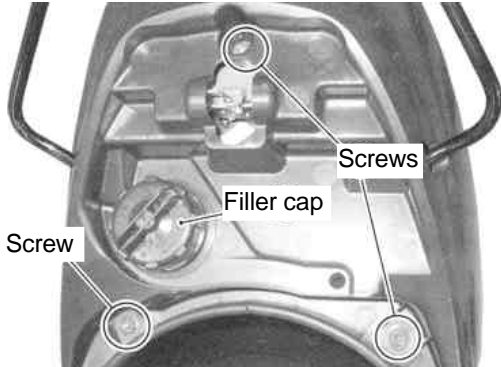

- 2 . Detach a O₂-type sensor coupler, and a O₂-type sensor lead wire from the clamp.

⚠ CAUTION :Take care not to give severe shock to the O₂-type sensor. When removing or installing the O₂-type sensor, be careful not to twist it harder than necessary. Also take care not to twist the sensor lead wire too much or damage it.

O₂-type sensor coupler

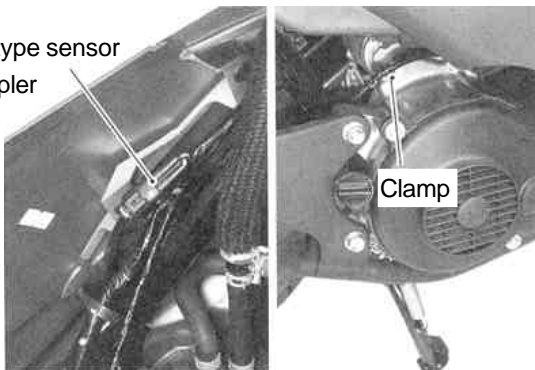

Removal of Genuine Muffler:

- 1 . Remove two exhaust pipe nuts connecting a cylinder and exhaust joint.

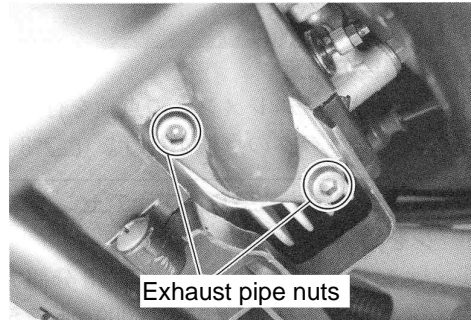

- 2 . Remove two muffler clamp bolts which are mounting the genuine muffler on the engine, and remove the muffler.
- 3 . Remove an old exhaust gasket in exhaust port.

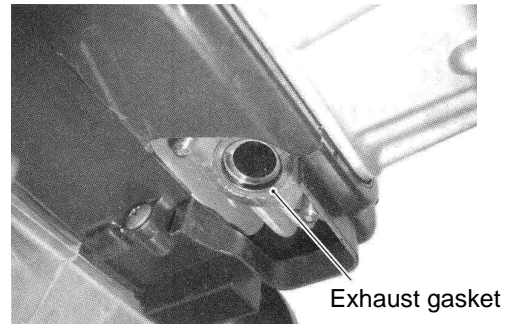

- 4 . Remove the O₂-type sensor from a genuine muffler.



Installation of Stay

- 1 . Fix a cushion rubber to the stay, and a collar to the cushion rubber.



- 2 . Mount the stay loosely for now with an M10x25 flange bolt.

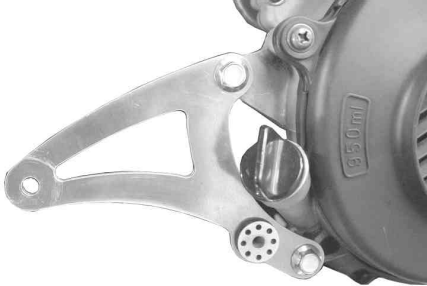

Installation of Bomber Muffler

- 1 . Install the O₂-type sensor to the BOMBER muffler.
Torque: 25 N·m (2.5 kgf·m)
- 2 . Install a provided exhaust gasket into the exhaust port.
- 3 . Align an exhaust pipe flange with a stud bolt on the cylinder head, and tighten it with an exhaust pipe nut for the moment.
- 4 . Wind a band rubber around a silencer band, and attach a clamp band to the silencer on the muffler COMP.



- 5 . Attach the silencer band to the stay with an 8x20 flange bolt and M8 flange nut, sandwiching the stay.



- 6 . Fit a 6x25 flange bolt into the collar attached to the stay, and install for now the exhaust pipe on the muffler COMP. with an M6 flange nut.



- 7 . Tighten the exhaust pipe nut to the specified torque.
Torque: 23 N·m (2.3 kgf·m)
- 8 . Fully tighten the 10x25 flange bolt on the just-loosely-fastened stay to the specified torque of:
Torque: 29 N·m (2.9 kgf·m)
- 9 . Fully tighten the 8x20 flange bolt on the just-loosely-fastened silencer band to the specified torque of:
Torque: 23 N·m (2.3 kgf·m)
- 10 . Fully tighten the just-loosely-fastened 6x25 flange bolt to the specified torque of:
Torque: 10 N·m (1.0 kgf·m)
- 11 . Install the O₂-type sensor coupler and fix the O₂-type sensor lead wire to the clamp.
In routing the sensor lead wire, be careful not to route it tightly stretched.
- 12 . Install the trunk box in the reverse order of its removal.
- 13 . Peel a protective film off a nameplate and a JMCA plate on the silencer.
(JMCA: Japan Motorcycle Accessories Association.)



- 14 . Thoroughly wipe off the dirt stuck on the muffler.
- 15 . Start the engine and check hardware for air exhaust leak.
⚠️WARNING :Be sure to start the engine in a well-ventilated place.
- 16 . Retighten hardware to the specified torque just for safety's sake.
⚠️CAUTION :Do the work only when the engine and muffler are cool.
⚠️CAUTION :Be sure to follow the specified torque.
- 17 . As for a bike with a normal engine, please change weight rollers referring to the installation instructions in the attached sheet.
If the rubber become hardened with the heat, replace it / them with the repair part.

The weight rollers of our recommendation for use with this muffler are 6 pieces of 15 g weight rollers provided in this Kit. Furthermore, the suitable weight of weight rollers varies according to the use of your motorcycle. So, arrange the weight rollers to match how you are going to ride your motorcycle.

~ Change of Weight Rollers ~

- 1 . Unfasten a tapping screw to remove a belt-cooling duct cover.

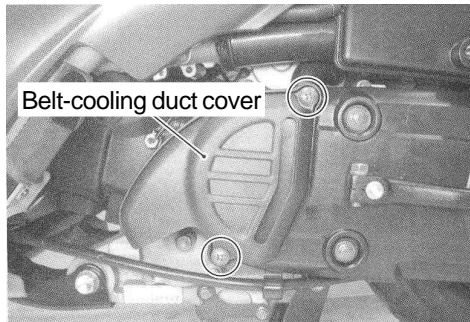

- 2 . Remove a kick-starter lever.

Torque: 13 N·m (1.3 kgf·m)

Unscrew a clutch outer bolt to remove a clutch outer cover.

Torque: 8N·m (0.8 kgf·m)

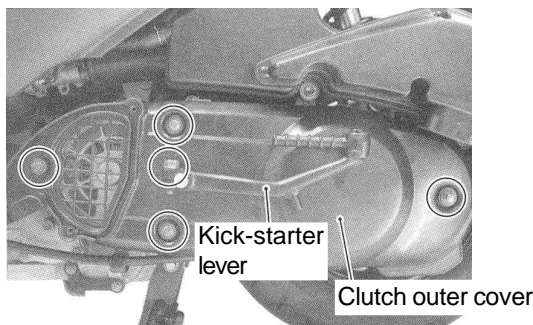

- 3 . Unscrew a clutch cover bolt to remove a clutch cover.

Torque: 10 N·m (1.0 kgf·m)

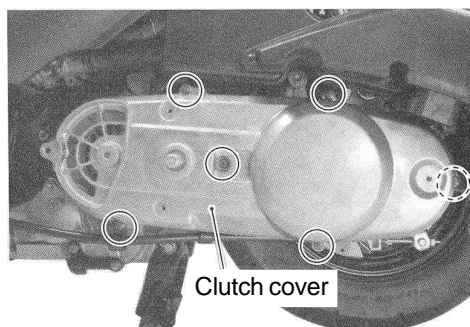

- 4 . Remove a gasket and dowel pins.

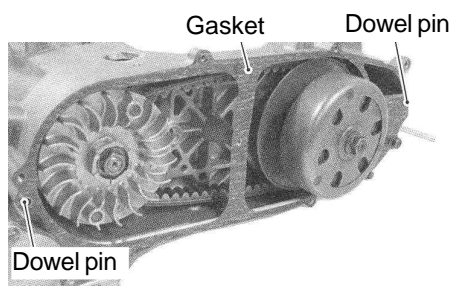

- 5 . With a special tool, unscrew a fixed drive face nut.

Torque: 50 N·m (5.0 kgf·m)

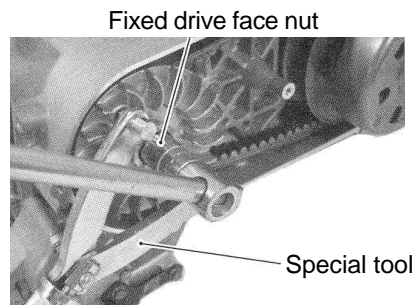

< Special tool > Universal holder: 00-01-1002

- 6 . Remove a spacer and movable drive face, and change the stock weight rollers with the supplied weight rollers of 15 g.

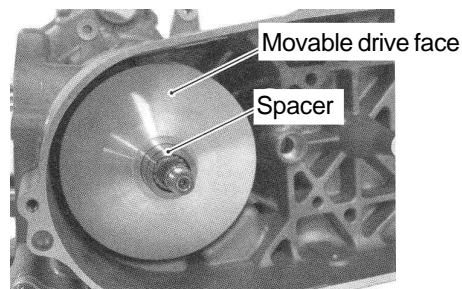

Install supplied six weight rollers.

Install a weight roller, seeing to it that they are placed in the right direction.

As shown in the figure below, the weight-roller outer, or the portion made of resin, comes in two upper corners: folded-down corner and not folded-down corner.

Install the weight rollers in the position so the folded-down corners face the reverse side of the pulley rotation as shown in the figure below.

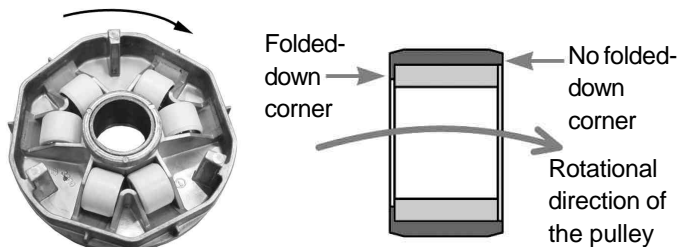

⚠ CAUTION :If the weight rollers are installed the other way round and when they get worn down, the contact of the inners and the pulley takes place, damaging the rubbing surface of the pulley against the inner, damaging the pulley, and causing the malfunction in converting the drive position.

Be careful that no oil or grease will stain the movable drive face or spacer. Be sure to degrease the face or spacer whenever stained with oil or grease.

- 7 . Install back the removed hardware in the reverse order of removal. Be sure to follow the specified torque at each paragraph, and do the installation work correctly.

SPECIAL PARTS TAKEGAWA Co.,Ltd.

3-5-16 Nishikiorihigashi Tondabayashi Osaka Japan

TEL : 81-721-25-1357 FAX : 81-721-24-5059

URL : <http://www.takegawa.co.jp>