



Inner Rotor C.D.I. Kit Instruction Manual

Only for racing purpose (for Twin Stark Head)

Item No.	Applicable models and fram Nos.
0 5 0 2 0 5 2 1 for R-type crank	:12V Monkey / Gorilla Z50J-2000001 ~ AB27-1000001 ~
0 5 0 2 0 3 2 1 for L-type crank	:Monkey BAJA / R / RT :6V Monkey / Gorilla Z50J-1323947 ~ 1805927
Limited to use with TAKEGAWA's Twin Spark Super Head.	

Thank you for purchasing one of our TAKEGAWA's products. Please strictly follow the following instructions in installing and using the products. Before fitting the products, please be sure to check the contents of the kit. Should you have any questions about the products, please kindly contact your dealer.

Please read the following instructions before installation.

Since this product is designed for exclusive use in racing, please be informed that we shall be held free from any after-sales responsibility whatsoever.

Any lamp or light can never be used.

You are kindly requested not to contact us about the combination of our products with other manufacturers'.

Please use our TAKEGAWA's own flywheel puller (Item No. 00-01-031) in detaching a rotor included in this kit.

Since all stock ignition system is to be removed, confirmation of valve timing at the "T" mark on the flywheel becomes impossible. Therefore, check and adjust the valve timing with a timing protractor (circular protractor, Item No. 00-01-0062).

The high-powered engine increases the heat release value. For this reason, the stator coil will become so hot that the coil may be damaged.

Therefore, process the generator cover to bore vents for cooling and exhaust in order to keep the stator as cool as possible.



CAUTION

The following show the envisioned possibility of injuries to human bodies and property loss as a result of disregarding the following cautions.

- Work only when the engine and the muffler are cool. (Otherwise, you will burn yourself.)
- Prepare right tools for the work, and do the work in the proper and right way. (Otherwise, improper work could cause breakage of parts or injuries to yourself.)
- Always use a torque wrench to screw bolts and nuts tight and securely to the specified torque. (Improper torque could cause these parts to get damaged or fall off.)
- As some products and frames have sharp-pointed or protruding portions, please work with your hands protected. (Otherwise, you will suffer injuries.)
- Before riding, always check every section for slack in parts like screws. If you find slack ones, screw them securely up to the specified torque. (Or improper torque may cause parts to come off.)
- Gaskets and packings must be replaced with new ones before riding. Besides, check carefully those parts to be reused, and in case wear or damage is detected, always replace them with new ones.



WARNING

The following show the envisioned possibility of human death or serious injuries to human bodies as a result of disregarding the following cautions.

- Always drive the engine in a well-ventilated place, and do not switch the engine on in an airtight place. (Otherwise, you will suffer from carbon monoxide poisoning.)
- Before doing work, place the motorcycle on level ground to stabilize the position of your motorcycle for safety's sake. (Otherwise, your motorcycle could fall down and injure you while you are working.)
- Check or perform maintenance of parts correctly according to the procedures in the instruction manual or a service manual. (Improper checking or maintenance could lead to an accident.)
- If you find damaged parts when checking and performing maintenance, do not use these parts any longer, and replace them with new ones. (The continued use of these damaged parts as they are could lead to an accident.)

Please be informed that, mainly because of improvement in performance, design changes, and cost increase, product specifications and prices are subject to change without prior notice.

A defective product which we acknowledge is caused by product materials or defect in manufacturing will be repaired or replaced with a new one, if and when a claim is filed with us within one (1) month of your purchase. However, replacing of parts shall be made at users' expenses.

And we shall be held free from responsibility for any defect caused by improper installation or use.

You are requested to keep this instruction manual until you discard this product.

~ Kit Contents ~

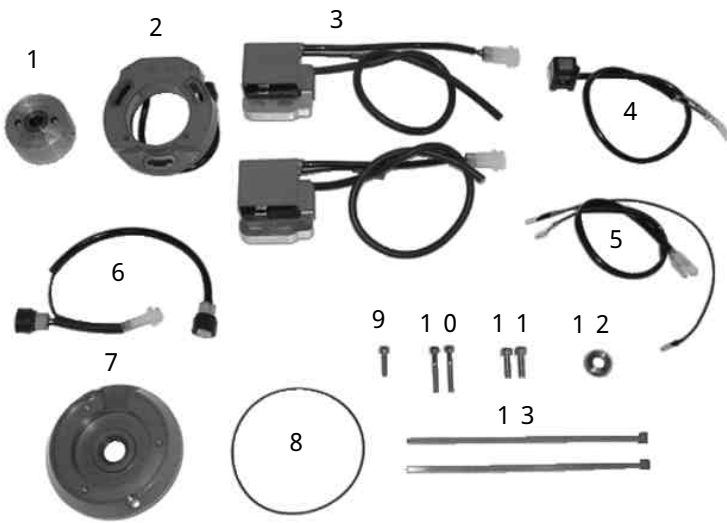

No.	Parts Name	Qty
1	Rotor	1
2	Stator	1
3	Ignition coils (CDI units)	2
4	Engine stop switch	1
5	Stop switch sub cord	1
6	Sub cord	1
7	Base plate	1
8	O-ring	1
9	Socket cap screw 5X20	1
10	Socket cap screws 5X35	2
11	Socket cap screws 6X20	2
12	Magnet fixing washer ()	1
13	Insulation locks 200mm	2
TOOLS	L-wrench 4mm	1
	L-wrench 5mm	1

#12 is available only for 05-02-0321 (L-type crank).

~ Installation Procedures ~

1. Check the contents of the kit.
2. Prepare tools for installation work.
3. Drain engine oil.
4. Remove the left side crank case cover, and remove the flywheel using a flywheel puller.
5. Remove wiring for a neutral switch and two flat screws, and pull out a stator assembly from the crank case.
6. Install an O-ring onto a base plate, and apply grease to the lip of the oil seal. Fix O-rings onto mounting bolts on the case, and fix the base plate with 6x20 socket cap screws.
Torque : 9N · m(0.9kgf · m)
The base plate must be fixed so its notch is on the plate's upper side.
When installing the base plate, apply grease lightly to the O-rings.
7. Install a stator onto the base plate by tightening socket cap screws.
Torque : 5N · m(0.5kgf · m)
8. Install a rotor onto the crank shaft. In the case of an L-type crank, tighten a nut, using a kit's magnet fixing washer. (Refer to the figure below.) In the case of an R-type crank, tighten the nut directly.
Torque : 41N · m(4.2kgf · m)
9. Remove a stock ignition coil and a wire harness, and fix a kit's ignition coil.
At this point, the ignition coil must be fixed so it can be grounded. Use a stock plug cap or the one included in the Twin Spark Super Head Kit.
10. Attach an engine stop switch to the handle pipe, and connect each cord. (Refer to the wiring diagram in the following page.)

~ About Ignition Timing ~

The initial timing slightly varies according to engine specifications. First, set the stator and the base plate, aligning the mark on the taper with the mark on the stator (see the fig. below). After testing how your motorcycle runs, adjust the position to gain the best effect. (We have set the stock at BTDC30 ;)

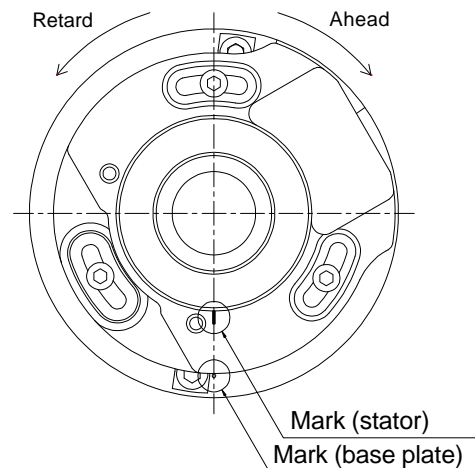
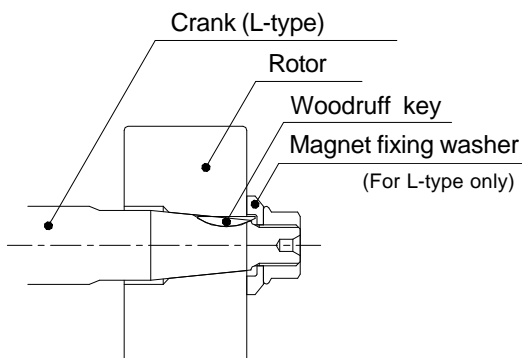

~ Wiring Diagram ~

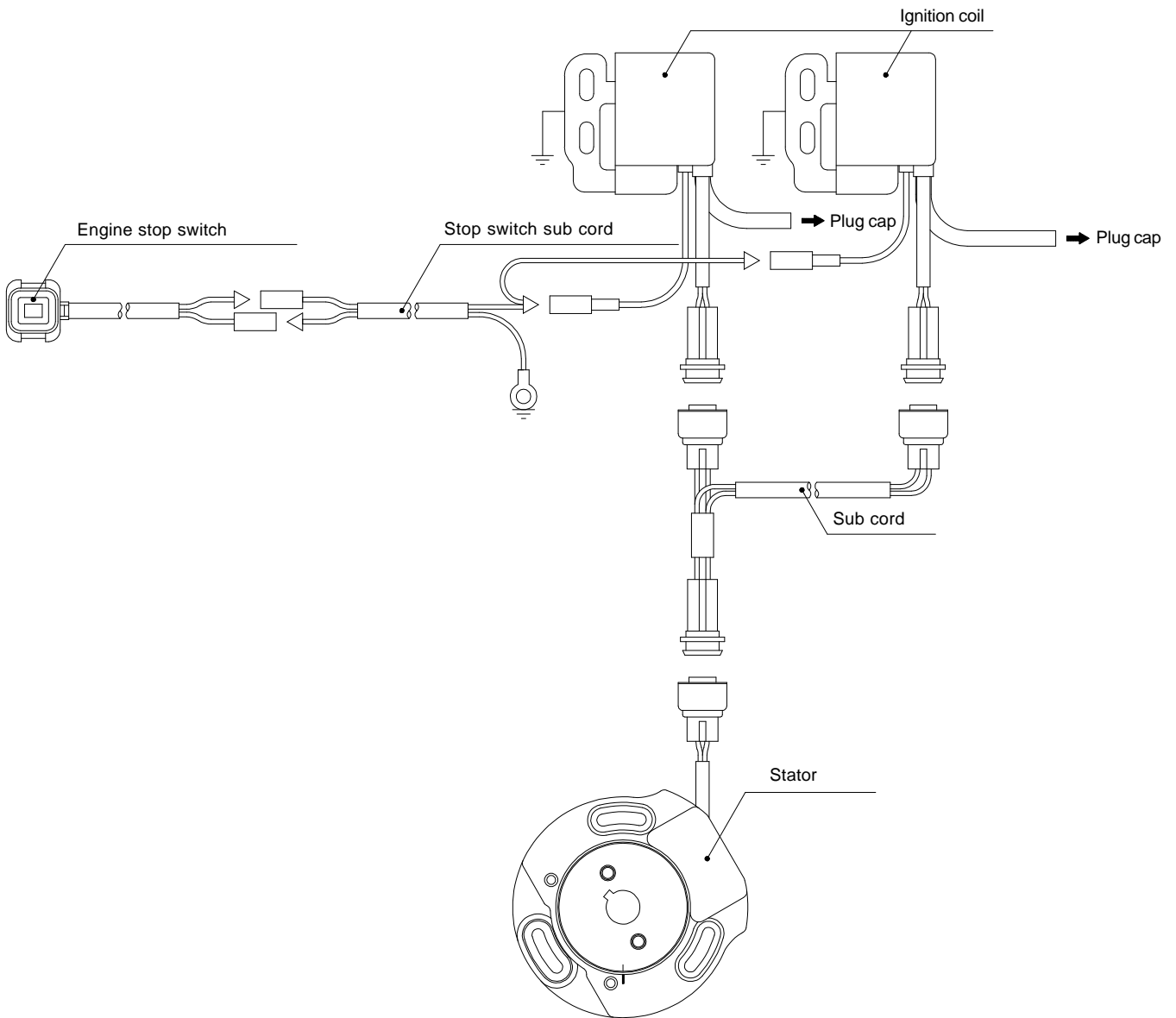

SPECIAL PARTS TAKEGAWA
3-5-16 Nishikiorihigashi Tondabayashi
Osaka Japan
TEL : 81-721-25-1357
FAX : 81-721-24-5059
URL : <http://www.takegawa.co.jp>