

# Aluminum Swing Arm

## (4cm longer, chain case bracket included) Instruction Manual

Product number 06-03-0102

Adaptation model	Monkey/Gorilla (6V)	(Z50J-1300017 ~ 1805927)
	Monkey/Gorilla (12V)	(Z50J-2000001 ~ ) (AB27-1000001 ~ )
	Monkey (FI)	(AB27-1900001 ~ )

Thank you very much for purchasing our products.

Thank you so you will comply with the following matters at the time of use. Before installation, please check your always kit contents. If there is a point of notice event, Please contact us the dealer of purchase.

◎ If the description, such as photos or Illustration different with this part.

☆ Please read carefully before use ☆

- ◎ The use ignoring the instructions that are written in the manual, if the accident or damage has occurred, we can not assume any responsibility for compensation.
- ◎ This product installation and use, when a problem occurs to after market goods, guarantee other than this product, also can not assume any in any such matters.
- ◎ If it was the case or mounting that has been processed like a product, it will not be covered under warranty.
- ◎ It is not possible to inquire of the combination of other manufacturers.
- ◎ This product is the above-mentioned vehicle exclusive goods. Is not possible attached to the other vehicle. Please note.
- ◎ Product may have edges or protrusions. Be sure to wear working gloves.  
(Please wear work gloves when working, even if a photo in this article show without work gloves.)
- ◎ During installation, it prepares the tool or the like, do the work with care in accordance with the mounting procedure. In addition, this manual and genuine service manual are intended for those who have a basic skills and knowledge. If no experience of mounting, etc., who preparation of such a tool is insufficient, we recommend that it is your request to the shop with a technical credit.
- ◎ Repair parts should apply in repair part number. Addition, any questions, please contact us to purchase.
- ◎ Before starting the installation, please read this Instruction Manual well for your thorough understanding and proper installation.

~ feature ~

- We have designed and produced this swing arm, fully utilizing the know-how obtained through the development of the MONKEY and the GORILLA over many years.  
The unsprung weight-saving and the combined use of this swing arm with a 280mm rear shock absorber have made the swing arm more stable than the standard ones. As this swing arm is only 4 cm longer than the standard ones, you can use the rear fender and other parts as they are. Thus, even after the installation of this product, the original form can still be maintained.
- A genuine chain case can be installed with just a few slight modifications to it. (However, there is no need to make any modifications to item No. 40510-165-000 for its installation.)
- For the installation of this product, you are required to replace the rear shock absorber with that of 280 mm.
- You are required to separately prepare a drive chain which has more links.
- A 10inch wheel cannot be installed.

**⚠ Caution** When the handling of ignoring this display, property damage and human shows the assumption of what injury.

- When performing the work, etc., be sure during the cold (when the engine and the muffler is cold). (It may cause burns.)
- When performing the work, it should be made to prepare the tools for the job. (Breakage of parts, it may cause injury.)
- Do the work must always specified torque using a torque wrench. (Damage of bolts and nuts, and cause of dropout.)
- The product and the frame, might have edges or protrusions. When working, please wear work gloves to protect your hands. (It may cause injury.)
- Be sure to each part inspection before operation, check the loosening of the threaded portion, be sure to securely tighten the specified torque if there is loose. (It may cause detachment of the parts.)

**⚠ Warning** When the handling of ignoring this display people died, shows the contents of the serious injury possibility is assumed.

- During operation, when an abnormality occurs, immediately stop the vehicle in a safe place, please stop running. (It may lead to an accident.)
- When performing the work, do the work safely stabilize the vehicle in a horizontal location. (There is a risk of injury vehicle collapsed while working.)
- Inspection, maintenance, the instruction manual or, inspection methods such as service manuals, to protect the way, should be done correctly. (unsuitable inspection and maintenance, there is a risk that result to an accident.)
- When carrying out the inspection and maintenance, etc., if found damaged parts, replace the damaged parts to avoid possible to reuse the parts. (There is a risk that lead to accidents Continued use.)
- Plastic bags of product packaging, you can either be stored in a place that is out of reach of children, it should be discarded. (When the children or wearing, there is a risk of suffocation.)
- Keep the brake drum and brake shoe clean of oil or grease. If any oil or grease adheres to them, replace the brake shoe with a new one and degrease the brake drum. (Otherwise, the adherence may lead to an accident.)

**SPECIAL PARTS**  
**TAKEGAWA**

CONTACT Address : 3-5-16 Nishikiorihigashi Tondabayashi Osaka JAPAN  
TEL: +81-721-25-1357 FAX: +81-721-24-5059 e-mail: english@takegawa.co.jp URL http://www.takegawa.co.jp  
Please contact with your name and country name provided. (Only English please)

- ◎ Please note. Performance up, the design change, the product and the price in the cost up, etc. are subject to change without notice.
- ◎ Please be informed that we shall be held harmless against any claim against us whatsoever arising out of use of the products in racing and the like.
- ◎ Keep this manual stored until this product is discarded.

Product content

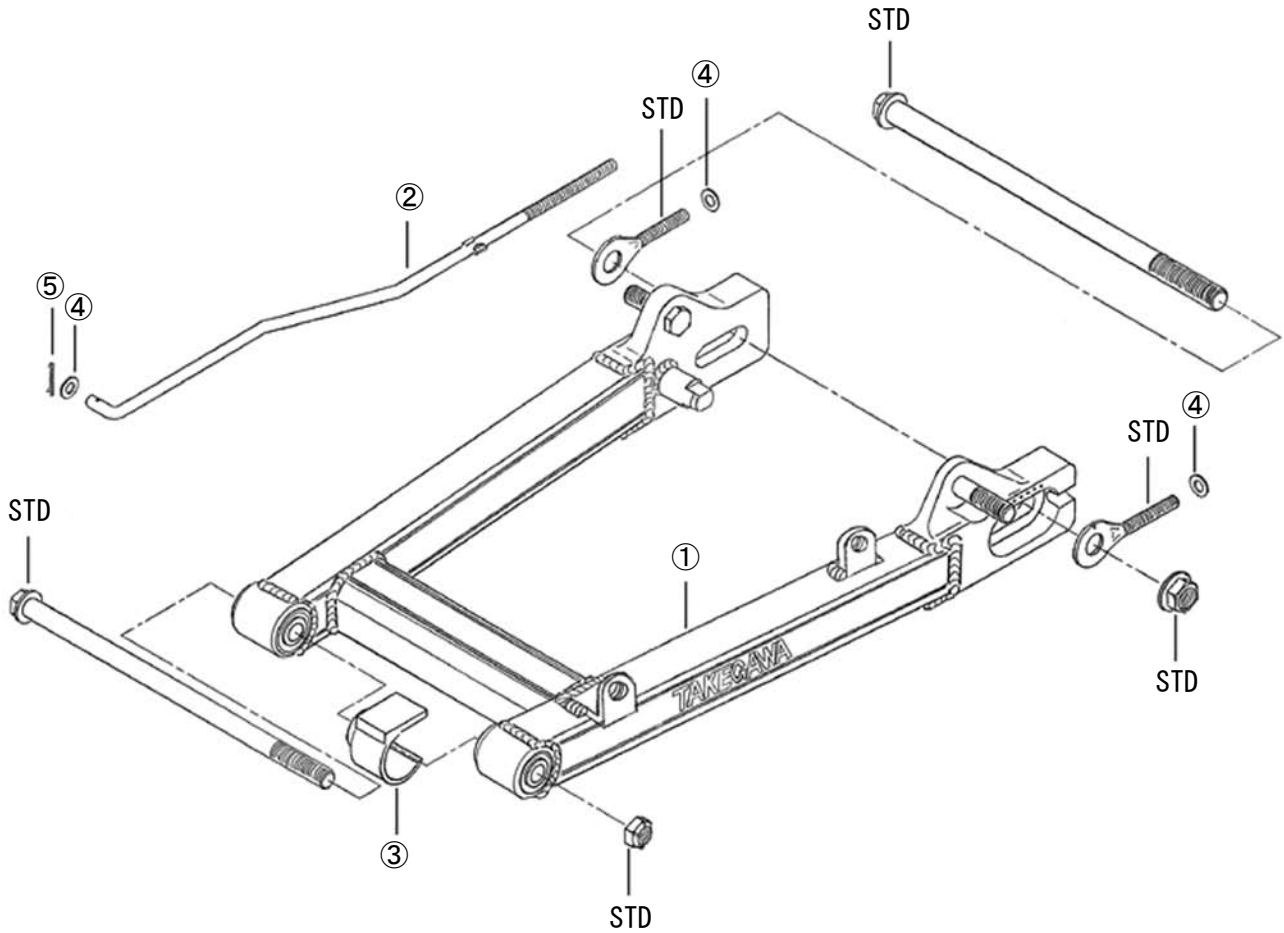

Number	Product content	Quantity	Item Number
1	Swing arm COMP.	1	_____
2	Brake rod	1	00-00-2503
3	Chain slider	1	00-06-0174
4	Plain washer, 6mm	3	00-00-0086 (10 pcs)
5	Split pin, 1.6x25	1	00-06-0018 (10 pcs)
	Plain washer, 10mm	2	00-00-0148 (5 pcs)

- ※ Please order in the repair parts are always repair part number.  
If it is not the part number order, you may not be able to order.  
Please be forewarned.  
It should be noted, In the case of parts that can not be separately shipment, please order a set part number.
- ※ Repair parts may differ slightly from the kit contents in terms of shape, etc.  
There is no problem to use it. Please be forewarned.

■ Mounting procedure ※ Please refer to the Genuine Service Manual for detailed mounting methods and specified torques that are not specifically described.

- Check the kit contents.
- Prepare proper tools for the installation work, and stabilize the vehicle securely.

▲ **WARNING:** Make sure your motorcycle is secure on level ground during installation.

- Remove a rear-brake-adjusting nut to remove a brake rod.
- Remove a rear axle nut to pull out an axle shaft.
- Detach a drive chain from the driven sprocket to demount a rear wheel.
- Remove a shock absorber.
- Remove a pivot nut on the rear fork, pull out the pivot shaft and remove a rear fork.
- Detach a clip on the drive chain and remove the chain.
- Attach a chain slider from within to a pivot on the chain side in the swing arm COMP., and install the swing arm to the frame, and loosely tighten for now the pivot shaft.
- Place a 280mm shock absorber upright. Holding a hexagonal bolt on the rear side with a screw wrench, tighten it to the specified torque.

▲ **Note:** Be sure that you protect specified torque.  
**Bolt**  
 Torque : 25 ~ 35N · m (2.5 ~ 3.5kgf · m)

- This is the case where a Z-style muffler is in use. To install a right-side shock absorber or on the side of the brake panel, put a 10mm plain washer (with shock absorber) between the swing arm and shock absorber on both top and bottom sides. And position the shock absorber and install it with a standard washer.

In the case of a Z-style muffler

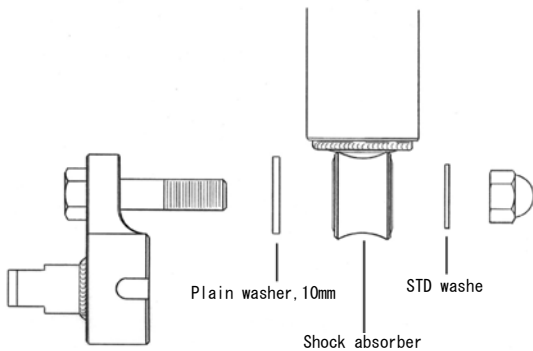

In the case of only a right-side shock absorber

- If a down muffler is in use, install the right-side shock absorber with a STD washer or 10mm plain washer.

In the case of a down muffler and others

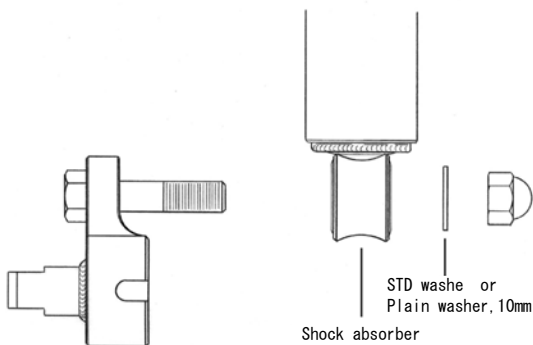

In the case of only a right-side shock absorber

- Tighten the nut on the pivot shaft to the specified torque.

▲ **Note:** Be sure that you protect specified torque.  
**Nut**  
 Torque : 25 ~ 35N · m (2.5 ~ 3.5kgf · m)

- Apply a thin coat of grease to the rear axle shaft, and place a chain adjuster at each side. And install a rear wheel and tighten a rear axle nut loosely for now.

▲ **WARNING:** Keep the lining surface inside the brake drum clean of any oil or grease. If any oil or grease adheres, degrease the brake drum and replace the brake shoe with a new one.

- Place a chain, which has many links, on the sprocket, and cut it with a chain cutter to match the sprocket.

▲ **Note:** Attach the clip onto the drive chain in the right direction.

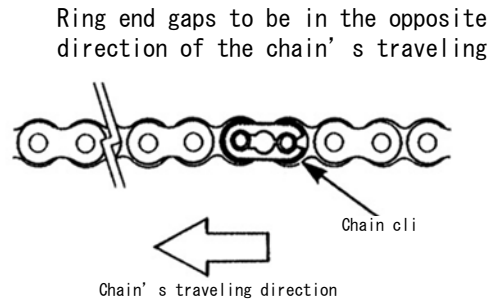

- Adjust the tension on the drive chain. Attach a nut to the chain adjuster just the way you do with a standard chain. (When installing onto the FI Monkey, attach an included plain washer and a nut to the chain adjuster.) Adjust the tension of the drive chain to have about 10 to 20 mm of free play when measured at a midway point between two sprockets.

▲ **Note:** Set the alignment marks on both chain adjusters on the right and left at the same scale marks.

- Tighten the rear axle nut to the specified torque.

▲ **Note:** Be sure that you protect specified torque.  
**Rear axle nut**  
 Torque : 40 ~ 50N · m (4.0 ~ 5.0kgf · m)

- Tighten up the chain-adjusting nut.
- Attach a brake rod, and adjust the free play at a rear brake pedal by turning the adjusting nut to the right and left.
- ※ Free play: 10 to 20 mm
- Double-check the tightening torque of the related parts and the free-play ranges, and wipe off dirt or dust on the parts.
- In the case of installing the genuine chain case of 40510-165-000, you can install it in the same way as installing it onto a standard swing arm.



- In the case of installing the chain case of 40510-165-730, cut off the shaded portion as shown in the photo below.
- ※ This product does not come with a chain case or a flange bolt. Please separately purchase genuine ones.
- ※ In some cases, the portion to be modified may vary depending upon the dimensions of an installed rear shock absorber.



© You can see this instruction manual on our website as PDF data .  
 If this document hard to read, please download it from our website.

