



## ZOOMER Speed meter & Stay Kit Instruction Manual

Item No.	: 0 9 - 0 1 - 0 2 8 0	White & Black type Speed Meter
	: 0 9 - 0 1 - 0 2 8 1	Black & Green type Speed Meter
	: 0 9 - 0 1 - 0 2 8 4	LED type Speed Meter
	: 0 9 0 1 0 0 5 6	LCD Speed & Tacho Meter
Applicable to	: ZOOMER	
Frame No.	: AF58-1000001 ~	

Thank you for purchasing one of our products. Please strictly follow the following instructions in installing and using the products. Before fitting the products, please be sure to check the contents of the kit. Should you have any questions about the products, please kindly contact your dealer.

**Please note: Illustrations and photos may vary from actual hardware.**

### ~ Features ~

0 9 0 1 0 2 8 0

Small-sized meter, using a white meter panel, with an odometer with the max reading of 140 km/h.

0 9 0 1 0 2 8 1

Speed meter, using a black meter panel with an odometer and a trip meter with the max reading of 160 km/h.

0 9 0 1 0 2 8 4

Speed meter, using a blue backlight LED with an odometer with the max reading of 140 km/h.

0 9 0 1 0 0 5 6

This meter with an LCD display and a blue LED backlight completely changes the visual effects around meters. This is a three-in-one meter, comprising of a speed meter, a tachometer and an odometer.

### Please read the following instructions before installation.

We do not take any responsibility for any accident or damage whatsoever arising from the use of the products not in conformity with the instructions in the manual.

We shall be held free from any responsibility or compensation whatsoever for any glitch in parts other than ours if the glitch takes place after installation and use of this product.

If you make alterations to the product outside our factory, we shall be held free from any guarantee of the product.

You are kindly requested not to contact us about the combination of our products with other manufacturers'.

Never use this product together with other manufacturers'. Otherwise, parts may be broken.

Please use this LCD meter with the following precautions in your mind:

- A liquid crystal display on the meter has characteristics that it tends to turn dark when exposed to the sunlight for long hours. Please take care not to leave it subjected to the direct sunlight. If it should become dark, keep it away from the direct sunlight and cool it, and the display will return to its original brightness before long. But it is likely that spots may remain on the display as aftereffects particularly when the display is left exposed to the strong direct sunlight for a long time in midsummer, which please take note.
- This product is not perfectly waterproofed. The use in a highly humid atmosphere will likely result in images getting blurred because the meter gets wet inside. If the images get blurred, shift a rubber cap around the wiring cords on the back of the meter toward yourself (do it with care not to pull the wirings forcibly) to make an opening and dry the moisture.



The following show the envisioned possibility of injuries to human bodies and property loss as a result of disregarding the following cautions.

- Please take note that the speed alarming function will be lost with the installation of this meter. Always try to drive your motorcycle at a legal speed, abiding by the laws.
- Work only when the engine and the muffler are cool. (Otherwise, you will burn yourself.)
- Prepare right tools for the work, and do the work in the proper and right way.  
(Otherwise, improper work could cause breakage of parts or injuries to yourself.)
- As some products and frames have sharp-pointed or protruding portions, please work with your hands protected.  
(Otherwise, you will suffer injuries.)
- Always use a torque wrench to screw bolts and nuts tight and securely to the specified torque.  
(Improper torque could cause these parts to get damaged or fall off.)
- Before riding, always check every section for slack in parts like screws. If you find slack ones, screw them securely up to the specified torque. (Or improper torque may cause parts to come off.)

**WARNING**

The following show the envisioned possibility of human death or serious injuries to human bodies as a result of disregarding the following cautions.

- Always drive the engine in a well-ventilated place, and do not switch the engine on in an airtight place. (Otherwise, you will suffer from carbon monoxide poisoning.)
- When you notice something abnormal with your motorcycle while riding down a road, stop riding immediately and park your motorcycle in a safe place. (Otherwise, the abnormality could lead to an accident.)
- Before doing work, place the motorcycle on level ground to stabilize the position of your motorcycle for safety's sake. (Otherwise, your motorcycle could fall down and injure you while you are working.)
- If you find damaged parts when checking and performing maintenance, do not use these parts any longer, and replace them with new ones. (The continued use of these damaged parts as they are could lead to an accident.)

Please be informed that, mainly because of improvement in performance, design changes, and cost increase, the product specifications and prices are subject to change without prior notice.

This manual should be retained for future reference.

~ Kit Contents ~

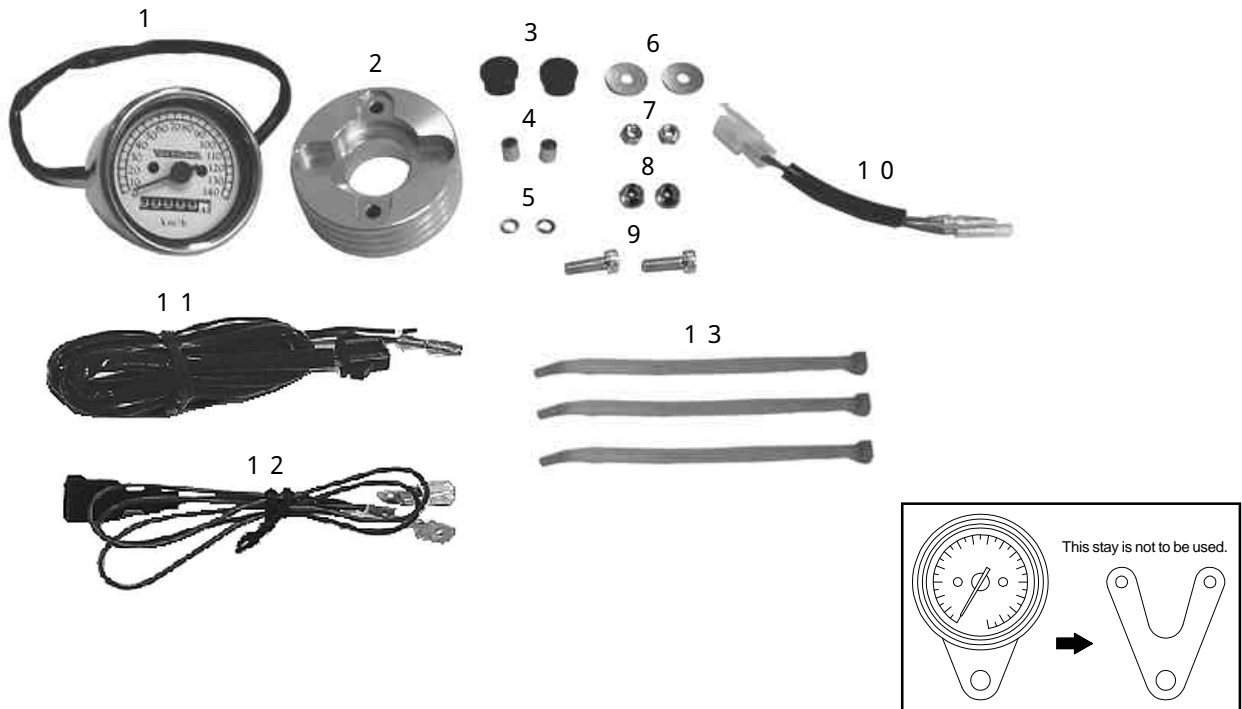

No.	Part Name	Qty															
		09	01	02	80	09	01	02	81	09	01	02	84	09	01	00	56
1	Meter assembly		1				1				1						1
2	Meter stay		1				1				1						1
3	Cushion rubber			2			2				2						2
4	8.5mm collar			2			2				2						2
5	5mm spring washer			2			2				2						
6	5x18 plain washer			2			2				2						2
7	5mm hex nut			2			2				2						
8	5mm hex flange nut																2
9	5x16 flange nut screw			2			2				2						2
10	Sub cord			1			1				1						1
11	Power supply cord																1
12	Pulse input cord																1
13	100mm insulation lock																3

Please use the parts #5, 7, and 8 attached to each meter.

## ~ Installation Procedures ~

- 1 . Loosen four screws which are fixing a front inner cover, detach two of its hooks from the front cover, and remove the front inner cover.



- 2 . Remove a wire band on the front cover which is fixing a blinker and headlight's cords, and disconnect a blinker connector and a headlight coupler.

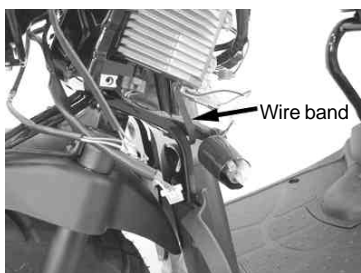

- 3 . Unscrew three headlight bracket mounting bolts and two front cover mounting screws, and remove the headlight bracket and the front cover.



- 4 . Disconnect a 3P white coupler and a black cord in the meter, and remove meter cables from the meter.



- 5 . Loosen a wire band binding meter cords, unscrew two meter mounting nuts, and detach the meter from the handle.



- 6 . Pass a meter assembly's (#1) cord through the upper central hole on the meter stay (#2), and fit two meter mounting bolts into two holes.  
CAUTION: Pay attention to the direction of the meter stay.

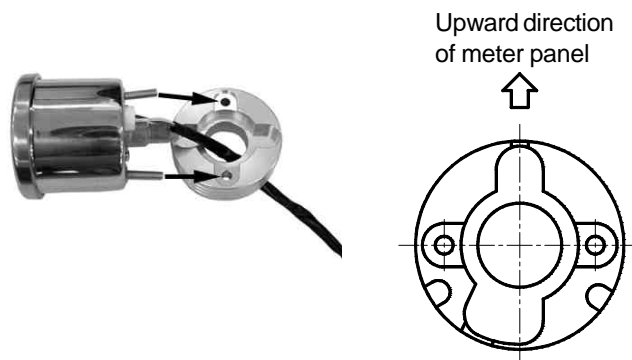

- 7 a . For 09-01-0280 · 0281 · 0284

Fix and tighten, with a socket wrench, spring washers (#5) and hex nuts (#7) in this order onto the meter mounting bolts from the back of the meter stay (#2).

CAUTION: Be sure to tighten to the specified torque.

**5mm hex nuts T=5 N · m (0.5 kgf · m)**



- 7 b . For 09-01-0056

Fix and tighten, with a socket wrench, hex flange nuts (#8) onto the meter mounting bolts from the back of the meter stay (#2).

CAUTION: Be sure to tighten to the specified torque.

**5mm hex flange nuts T=5 N · m (0.5 kgf · m)**

- 8 . After removing rubbers from the handle's meter stay, install cushion rubbers (#3), and fix collars (#4) to the cushion rubbers.



- 9 . Connect the speed meter cable with the meter.



- 1 0 . Mount the speed meter, assembled as per the previous paragraph 7, on the handle's meter stay, and tighten socket cap screws (#9) and plain washers (#6) in this order.

CAUTION: Be sure to tighten to the specified torque.

**5x16 socket cap screws T=4 N · m(0.4 kgf · m)**



- 1 1 a . For 09-01-0280

Connect a meter assembly cord (#1) with a sub cord (#10), and then a 3P coupler of a sub cord with a 3P coupler of a meter-lighting cord on the body.

As the negative electricity to the meter assembly (#1) is supplied through the speed meter cable, so green sub cord (#10) is not used.

Meter assembly (#1)	Sub cord (#10)
Brown	( + ) Brown
Body earth ( Meter cable )	( - ) Green

- 1 1 b . For 09-01-0281

Connect a meter assembly cord (#1) with a sub cord (#10), and then a 3P coupler of a sub cord with a 3P coupler of a meter-lighting cord on the body.

Meter assembly (#1)	Sub cord (#10)
Brown	( + ) Brown
Green	( - ) Green

- 1 1 c . For 09-01-0284

Connect a meter assembly cord (#1) with a sub cord (#10), and then a 3P coupler of a sub cord with a 3P coupler of a meter-lighting cord on the bod

Meter assembly (#1)	Sub cord (#10)
Black	( + ) Brown
Green	( - ) Green

- 1 1 d . For 09-01-0056

Connect a black coupler of a meter assembly cord with a black coupler of the power source cord (#12). Connect red and black cords of the power source cord (#12) with brown and green sub cords (#10).

Connect a white 3P coupler of a sub cord (#10) with a 3P coupler of a meter-lighting cord on the body.

Power source cord (#12)	Sub cord (#10)
Red	( + ) Brown
Black	( - ) Green

- 1 2 . For 09-01-0056

Unscrew six seat-frame-mounting bolts, and remove the seat frame from the body.

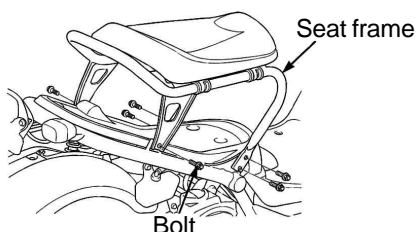

- 1 3 . For 09-01-0056

Remove the mud guard and the floor panel in the alphabetical order as shown in the fig. below.

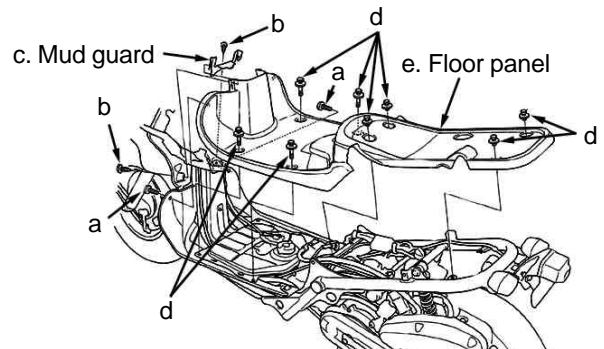

- 1 4 . For 09-01-0056

Take out a black and yellow cords of the ignition coil, and fit a pulse input cord (#12) into a place between them.

Pull a pulse input cord with a round female plug close to a meter along a frame, and connect it with a brown power supply cord (#11).

Fix the cord, pulled along the frame, at two points with insulation locks (#13) so the cord will not slacken. Then, bind the surplus portion of the cord together with an insulation lock (#13) inside the front cover.

The unnecessary portion of insulation lock tips should be cut off with a nipper or the like.

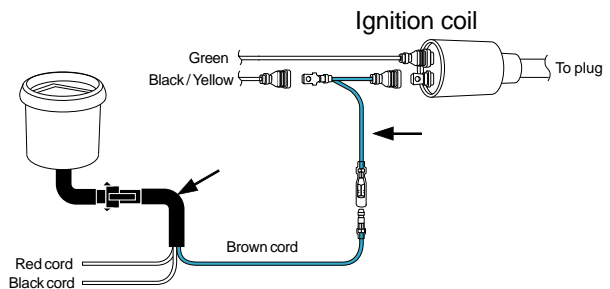

- 1 5 . Start the engine, and check whether the meter lights or not. If it does not light, there is a possibility of a broken filament or poor cord connection, which please check.

⚠ WARNING: Always drive the engine in a well-ventilated place.

- 1 6 . Reinstall the exterior parts in the reverse order of their removal. However, the mud guard should be installed in the following way. (Refer to the figs. A and B.)

- A . Shifting two cables toward the rear side, fit the hooks at the tips of two mud guards into the grooves on the floor panel, and set the center of it under the boss of a frame.
- B . Fit the convex sides of the hooks at the end of the mud guards securely into the grooves on the floor panel.

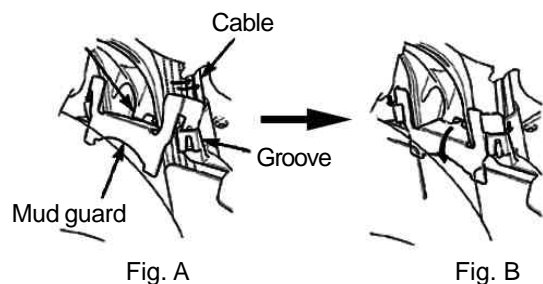

**SPECIAL PARTS TAKEGAWA** Co.,Ltd.

3-5-16 Nishikiorihigashi Tondabayashi Osaka Japan

TEL : 81-721-25-1357 FAX : 81-721-24-5059 URL : <http://www.takegawa.co.jp>

# type Addendum

## For tachometer set of large LCD meter

This page various kit common content.

Please switch the meter setting value according to appropriate vehicle.

Vehicle name	Product No.	CYC-	PIS-
MAGNA50	09-01-0211	2	1
ZOOMER (Carburetor vehicle)	09-01-0056	2	1
TODAY (Carburetor vehicle)	06-02-0303	2	1
AF62 Dio	06-02-0301	2	1
SPACY100	06-02-0305	2	1
Dio (two-cycle)	06-02-0302	2	1
JOG (two-cycle)	06-02-0304	2	1
XR50/100 Mptard	09-01-0288	2	1
XR250 Mptard	09-01-0055	2	1
KSR110	09-01-0054	2	1
KSR50/80	09-01-0054	2	2

### Setting change procedure of tachometer

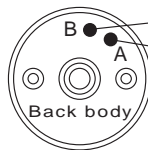

Numerical change button (in the text [B] button)  
Setting item switch button (in the text [A] button)



Turn ON the main key of vehicle (starting the engine by vehicle), please state the power of meter has entered (there is a LCD).

Then press the [A]

Press the button on the [A].  
Display of "CYC-" appears on the screen.  
In this case, will change display alternately with the time you press the button on [B] "CYC-2" "CYC-4".



Numerical change in [B]

To fit to the appropriate vehicle, please select either.  
After the selection of CYC- is now complete, please press

Then press the [A]

Display of "PIS-" appears on the screen.  
In this case right side of numerals of the time you press the button on [B] "PIS-" will change.  
Above - if you choose the "CYC 2" it will become a 1 2 3 4 1 2 ....  
It becomes 1 2 3 4 5 6 8 1 ... If also you have selected the "CYC-4".  
Depending on appropriate vehicle, please select.



Numerical change in [B]

Then press the [A]

All settings are complete, it will return to standard screen from setting change screen by pressing [A] button.

### Engine Type [CYC-], about number of cylinders [PIS-]

This [engine type, number of cylinders], an example of the ignition number of crankshaft rotation.  
Therefore, some cases be different from engine type and the number of cylinders of actual vehicle.

0.5 times represents the once ignition to the crank shaft 2 rotation.

Ignition number of times per crankshaft revolution	0.5 times	1 times	1.5 times	2 times	2.5 times	3 times	4 times
CYC-2 (For example of two-cycle engine)		PIS-1		PIS-2		PIS-3	PIS-4
CYC-4 (For example of four-cycle engine)	PIS-1	PIS-2	PIS-3	PIS-4	PIS-5	PIS-6	PIS-8

( PIS- the example of the number of cylinders )

When ignition number of appropriate vehicle do not know  
Engine types in [CYC-2] fixed, first set the number of cylinders in [PIS-4], please check the display numeric value by lightly blip the engine.

The number of cylinders [PIS-4] in because it is often actually displayed less than, we will display number is increased by changing the PIS-3 PIS-2 PIS-1 and numbers while watching a state, it becomes just a good set .

Monkey-based engine, Ape-based engine, other four-stroke 1 cylinder, many four-cylinder engine is set because it is one ignition per rotation crank shaft 1 will be [CYC-2, PIS-1].

In the part of the two-stroke one cylinder of vehicle and the inner rotor mounted vehicle, there is a case of ignition twice per crankshaft revolution [CYC-2, PIS-2].